



FOOD MIXER BM-5E 230/50-60/1

Table-top model with 5-lt / qt. bowl.



P/N 1500180



DYNAMIC PREPARATION
PLANETARY MIXERS

SALES DESCRIPTION

Designed for light duty use.

- ✓ Professional food mixer for preparing dough (bread, cake...), egg whites (soufflés, meringue...), sauces (mayonnaise...) and minced meat mixtures.
- ✓ Equipped with an extractable safety guard.
- ✓ Continuous variable electronic speed control.
- ✓ Lever operated bowl lift.
- ✓ Double micro switch for bowl position and safety guard.
- ✓ NSF-International certified appliance (complying with Hygiene, Cleaning and Food Material regulations)

INCLUDES

- ✓ Stainless steel bowl.
- ✓ Beater spatula for soft dough.
- ✓ Spiral hook for heavy dough.
- ✓ Balloon whisk.

ACCESSORIES

- Bowls for planetary mixers



SAMMIC, S.L.
Basarte, 1 - 20720 AZKOITIA
www.sammic.com

sammic | www.sammic.com
Food Service Equipment Manufacturer

Polígono Basarte, 1. phone +34 943 15 72 36
20720 Azkoitia, Spain sales@sammic.com



Project	Date
Item	Qty
Approved	

product sheet
updated 21/04/2021



FOOD MIXER BM-5E 230/50-60/1

Table-top model with 5-lt / qt. bowl.



P/N 1500180

SPECIFICATIONS

Bowl capacity: 5 l

Capacity in flour (60% water): 1 Kg

Total loading: 300 W

Electrical supply: 230 V / 50-60 Hz / 1 ~
(2.2 A)

Plug: EU

External dimensions (WxDxH)

✓ Width: 310 mm

✓ Depth: 382 mm

✓ Height: 537 mm

Net weight: 13.7 Kg

Crated dimensions

360 x 430 x 565 mm

Gross weight: 17 Kg.

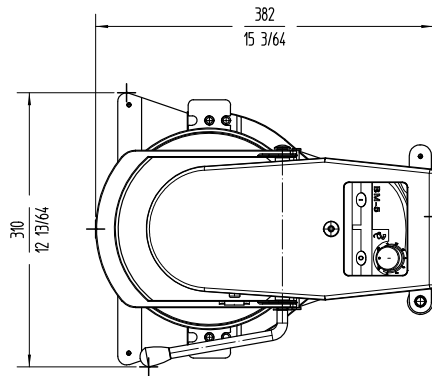
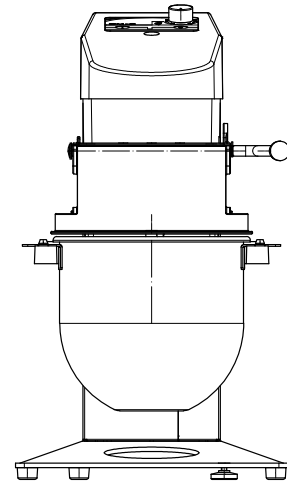
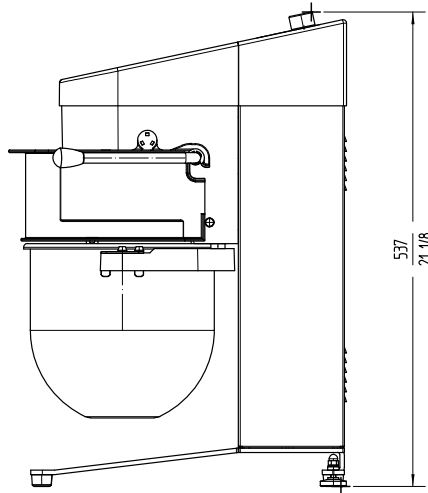

DYNAMIC PREPARATION
PLANETARY MIXERS

 **sammic** | www.sammic.com
Food Service Equipment Manufacturer

Polígono Basarte, 1.
20720 Azkoitia, Spain

phone +34 943 15 72 36
sales@sammic.com



Project

Date

Item

Qty

Approved

product sheet
updated 21/04/2021