

BAKER

REFRIGERATION

CAPTUR BT/TN

DUAL TEMPERATURE ISLAND DISPLAY CASE



CHILLER/FREEZER



R290



PLUG-IN

FEATURES INCLUDE

- Freezer or chiller modes
- Sliding glass lids
- Glass sides for optimal product viability
- Temperature selector switch
- Castor wheels
- LED lighting



Scan here to check for Energy Efficiency Rebates in your state.



Product image not to scale



REFRIGERATION

BONNET NÉVÉ CAPTUR BT/TN

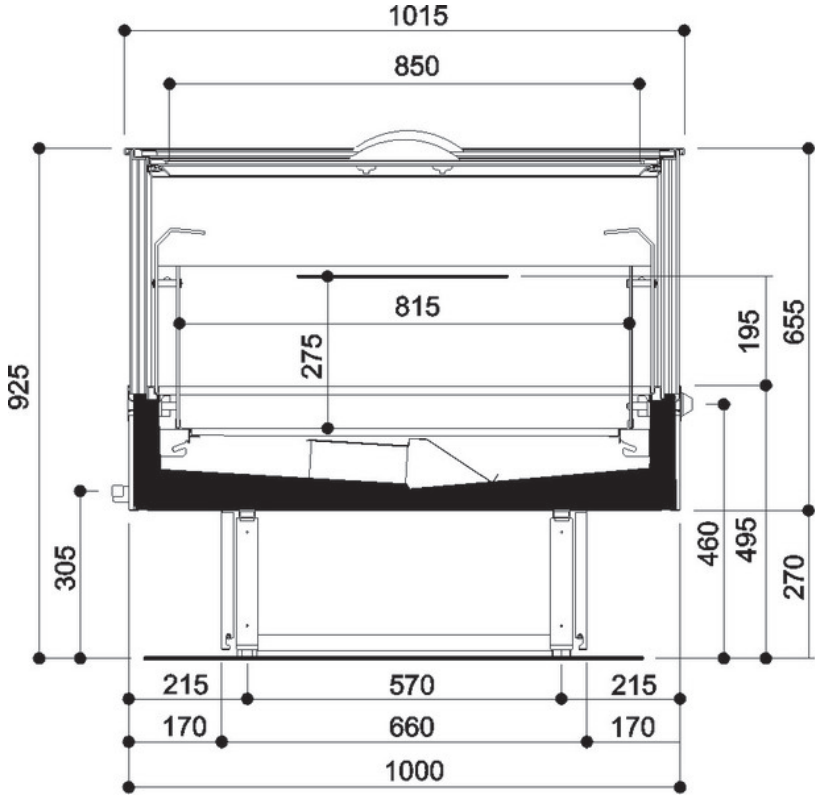

CAPTUR BT/TN	150	200
OPERATING TEMP (°C)	-18 / -24 / 0 / +2	
REFRIGERATION	Ventilated / R290	
DEFROST	Automatic	
POWER SUPPLY	230V / 1Ph / 10 Amp plug	
OPERATING CURRENT (Amp)	2.9 / 2.8	3.6 / 3.5
NOMINAL POWER (W)	650 / 642	810 / 783
ENERGY CONSUMPTION (kWh/24h)	11.7 / 11.5	14.6 / 14.1
DEFROST POWER (W)	1352 / 1233	1813 / 1665
TOTAL CAPACITY (ltr)	268	364
LENGTH INCLUDING BUMPER (mm)	1570	2070
HEIGHT WITHOUT CASTORS (mm)	925	925
HEIGHT INCLUDING CASTORS (mm)	980	980
DEPTH INCLUDING BUMPER (mm)	1015	1015
WEIGHT WITHOUT PACKAGING (kg)	175	202

* Climate class 3 (25 °C, 60% R/H) | Sliding lids to be used when in freezer mode

