

BTGOR6 TOWER SERIES OPEN FRONT REFRIGERATED

COSSIGA

BTGOR6



PRODUCT FEATURES

- Open front
- Stainless steel hinged rear door
- Deck forced refrigeration
- Double glazed glass ends
- Two adjustable glass shelves
- Flat or angled shelves
- Ticket strips on shelves and base
- Under shelf and canopy LED lights
- Integral condenser
- Pull down night blind
- Pigeon hole perspex screens

Maximum shelf load weight 15kg spread evenly
All units rear venting

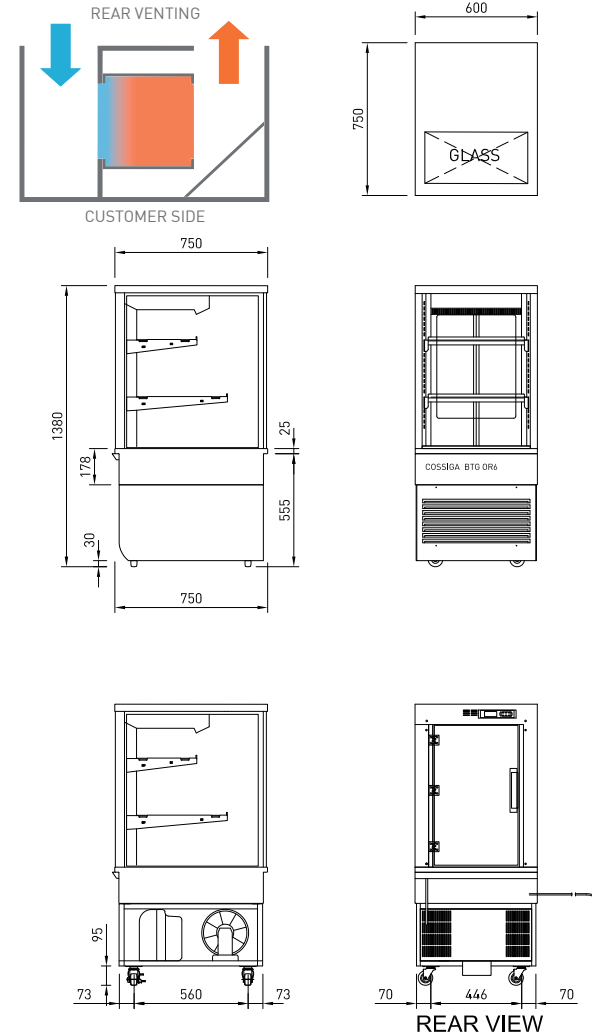

CABINET DIMENSIONS & SPECIFICATIONS

Prior to installation see, installation guidelines, ventilation requirements and drainage options documents

MODEL	CABINET				SHELVING	OPERATING TEMP	SHELF	BASE TRAY	TOTAL FOOD	DISPLAY M ²	INTERNAL VOLUME M ³	FREQUENCY	REFRIGERANT	POWER		CONNECTION ELECTRICAL POWER CORD 2200MM		VOLTAGE	PACKED FOR SHIPPING			
	LENGTH [MM]	DEPTH [MM]	HEIGHT [MM]	WEIGHT KG										DEG C	W X D	W X D	100MM UNITS		KW 230V	AMP	NZ/AUS 10 AMP	UK 13 AMP
BTGOR6	600	750	1380	175	2 + BASE	3-5	490 X 290 (TOP) 490 X 380 (2ND)	545 x 515	55	0.60	0.29	50/60 HZ	R290	1.38	6.0	3 PIN PLUG	3 PIN PLUG	220-240V	700	830	1550	166

BTGOR9 TOWER SERIES OPEN FRONT REFRIGERATED

COSSIGA

BTGOR9



PRODUCT FEATURES

- Open front
- Stainless steel hinged rear doors
- Deck forced refrigeration
- Double glazed glass ends
- Two adjustable glass shelves
- Flat or angled shelves
- Ticket strips on shelves and base
- Under shelf and canopy LED lights
- Integral condenser
- Pull down night blind
- Pigeon hole perspex screens

Maximum shelf load weight 15kg spread evenly
All units rear venting

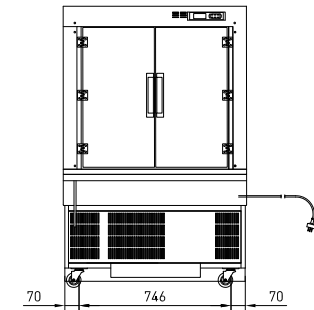
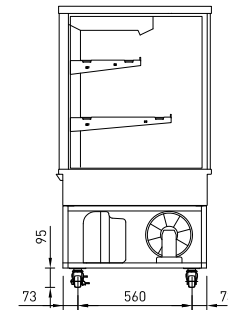
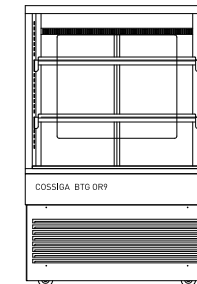
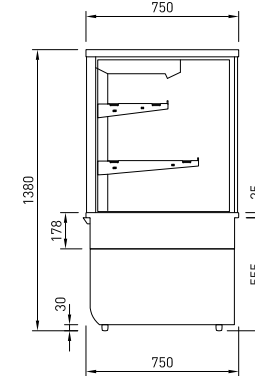
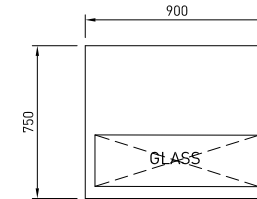
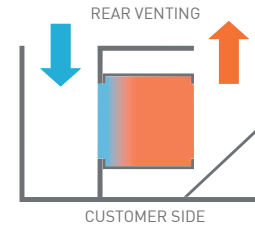

REAR VIEW

Prior to installation see, installation guidelines, ventilation requirements and drainage options documents

CABINET DIMENSIONS & SPECIFICATIONS

MODEL	CABINET				SHELVING	OPERATING TEMP	SHELF	BASE TRAY	TOTAL FOOD	DISPLAY M ²	INTERNAL VOLUME M ³	FREQUENCY	REFRIGERANT	POWER		CONNECTION ELECTRICAL POWER CORD 2200MM		VOLTAGE	PACKED FOR SHIPPING			
	LENGTH [MM]	DEPTH [MM]	HEIGHT [MM]	WEIGHT KG										DEG C	W X D	W X D	100MM UNITS		KW 230V	AMP	NZ/AUS 10 AMP	UK 13 AMP
BTGOR9	900	750	1380	224	2 + BASE	3-5	790 X 290 (TOP) 790 X 380 (2ND)	845 x 515	114	0.96	0.45	50/60 HZ	R290	1.33	5.8	3 PIN PLUG	3 PIN PLUG	220-240V	1000	830	1550	207

BTGOR12 TOWER SERIES OPEN FRONT REFRIGERATED

COSSIGA

BTGOR12



PRODUCT FEATURES

- Open front
- Stainless steel hinged rear doors
- Deck forced refrigeration
- Double glazed glass ends
- Two adjustable glass shelves
- Flat or angled shelves
- Ticket strips on shelves and base
- Under shelf and canopy LED lights
- Integral condenser
- Pull down night blind
- Pigeon hole perspex screens

Maximum shelf load weight 15kg spread evenly
All units rear venting

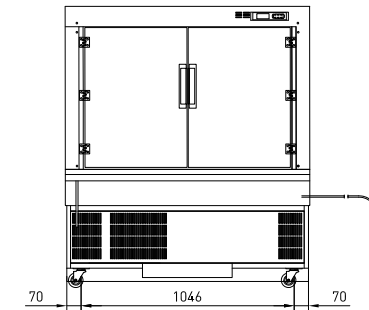
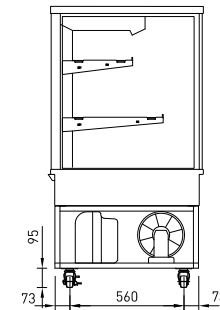
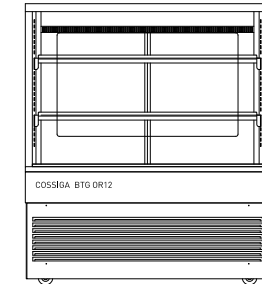
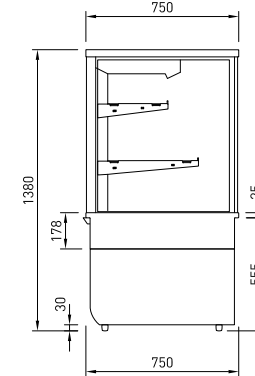
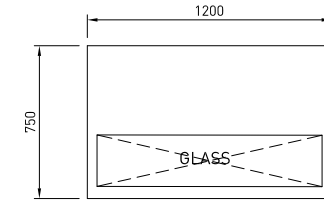
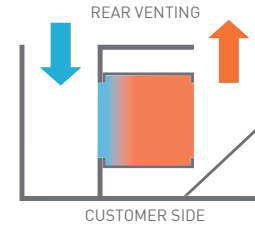

REAR VIEW

Prior to installation see, installation guidelines, ventilation requirements and drainage options documents

CABINET DIMENSIONS & SPECIFICATIONS

MODEL	CABINET				SHELVING	OPERATING TEMP	SHELF	BASE TRAY	TOTAL FOOD	DISPLAY M ²	INTERNAL VOLUME M ³	FREQUENCY	REFRIGERANT	POWER		CONNECTION ELECTRICAL POWER CORD 2200MM		VOLTAGE	PACKED FOR SHIPPING			
	LENGTH [MM]	DEPTH [MM]	HEIGHT [MM]	WEIGHT KG										DEG C	W X D	W X D	100MM UNITS		KW 230V	AMP	NZ/AUS 10 AMP	UK 13 AMP
BTGOR12	1200	750	1380	273	2 + BASE	3-5	1090 X 2 90 (TOP) 1090 X 380 (2ND)	1145 x 515	123	1.31	0.60	50/60 HZ	R290	1.74	7.6	3 PIN PLUG	3 PIN PLUG	220-240V	1300	830	1550	255

BTGOR15



PRODUCT FEATURES

- Open front
- Stainless steel hinged rear doors
- Deck forced refrigeration
- Double glazed glass ends
- Two adjustable glass shelves
- Flat or angled shelves
- Ticket strips on shelves and base
- Under shelf and canopy LED lights
- Integral condenser
- Pull down night blind
- Pigeon hole perspex screens

Maximum shelf load weight 15kg spread evenly
All units rear venting

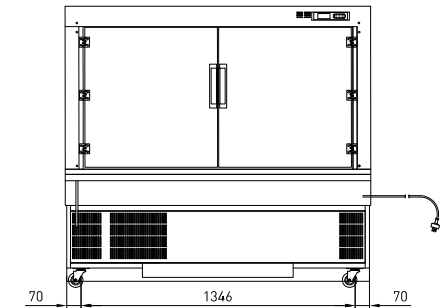
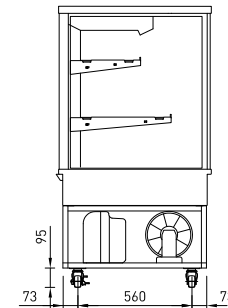
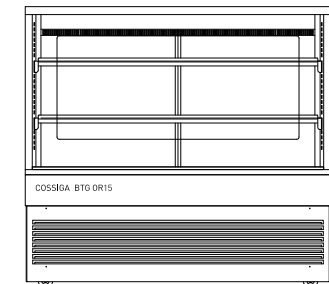
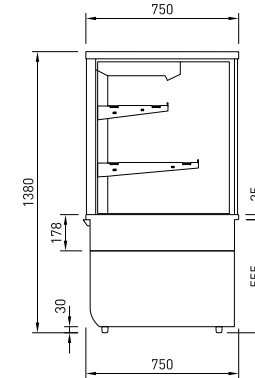
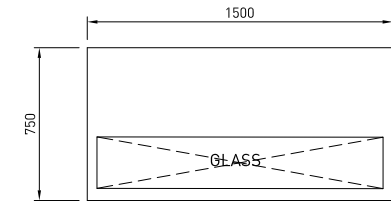
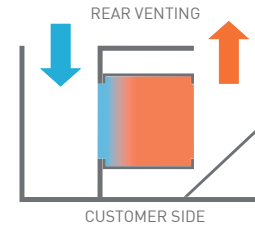

REAR VIEW

CABINET DIMENSIONS & SPECIFICATIONS

Prior to installation see, installation guidelines, ventilation requirements and drainage options documents

MODEL	CABINET				SHELVING	OPERATING TEMP	SHELF	BASE TRAY	TOTAL FOOD	DISPLAY M ²	INTERNAL VOLUME M ³	FREQUENCY	REFRIGERANT	POWER		CONNECTION ELECTRICAL POWER CORD 2200MM		VOLTAGE	PACKED FOR SHIPPING			
	LENGTH [MM]	DEPTH [MM]	HEIGHT [MM]	WEIGHT KG										DEG C	W X D	W X D	100MM UNITS		KW 230V	AMP	NZ/AUS 10 AMP	UK 13 AMP
BTGOR15	1500	750	1380	285	2 + BASE	3-5	1390 X 290 (TOP) 1390 X 380 (2ND)	1445x 515	168	1.67	0.75	50/60 HZ	R290	1.56	6.8	3 PIN PLUG	3 PIN PLUG	220-240V	1600	830	1550	291