

## MP40T

Mixer for pastry ice-cream parlour catering and bakery



### OPTIONS AND ACCESSORIES

- Reduction kit from 40lt to 10lt with nr. 3 accessories
- Reduction kit from 40lt to 20lt with nr. 3 accessories

### EXTERNAL CONSTRUCTION

- Structure in powder painted stainless steel
- Bowl and protections in stainless steel
- Replaceable whisk with thin stainless steel wires
- Spatula and spiralized hook in aluminium alloy
- Thick frame to avoid vibrations in every working phase
- Structure with adjustable rear stabilizers
- Protection grate equipped with sliding sheet for ingredients topping up
- Rotating protection grate easily removable for cleaning
- Push-button panel on top side
- General switch on right side

### INTERNAL CONSTRUCTION

- Three electric variations of the tool rotation speed
- Toothed belt driving
- Rotating parts of the transmission system on rolling bearings
- Electrical equipment with low-voltage auxiliary circuits
- Protection grate, arm and bowl in position limit switch
- Tools fast uncoupling
- Slides for the manual bowl uplift by leverage

### FUNCTIONING

- Dough homogeneity and oxygenation by the combined planetary rotating and eccentric movement of the tool
- Possibility to mix a maximum volume of 40lt
- The tools can whip mix and partially knead in few minutes different food products
- Removable bowl automatically fixed in working position

### STANDARD EQUIPMENT

- Whisk with thin wire
- Spatula
- Spiralized hook
- "French" shake bowl
- Lever for the manual bowl uplift
- 3 motor speeds
- Switching-off Timer



**MORETTI FORNI S.P.A.**

[www.morettiforni.com](http://www.morettiforni.com)

[info@morettiforni.com](mailto:info@morettiforni.com)

Via A.Meucci, 4 - 61037 Mondolfo (PU) ITALIA

Tel. +39.0721.96161 - Fax +39.0721.9616299



## MP40T

RIGHT SIDE VIEW

FRONTALE VIEW

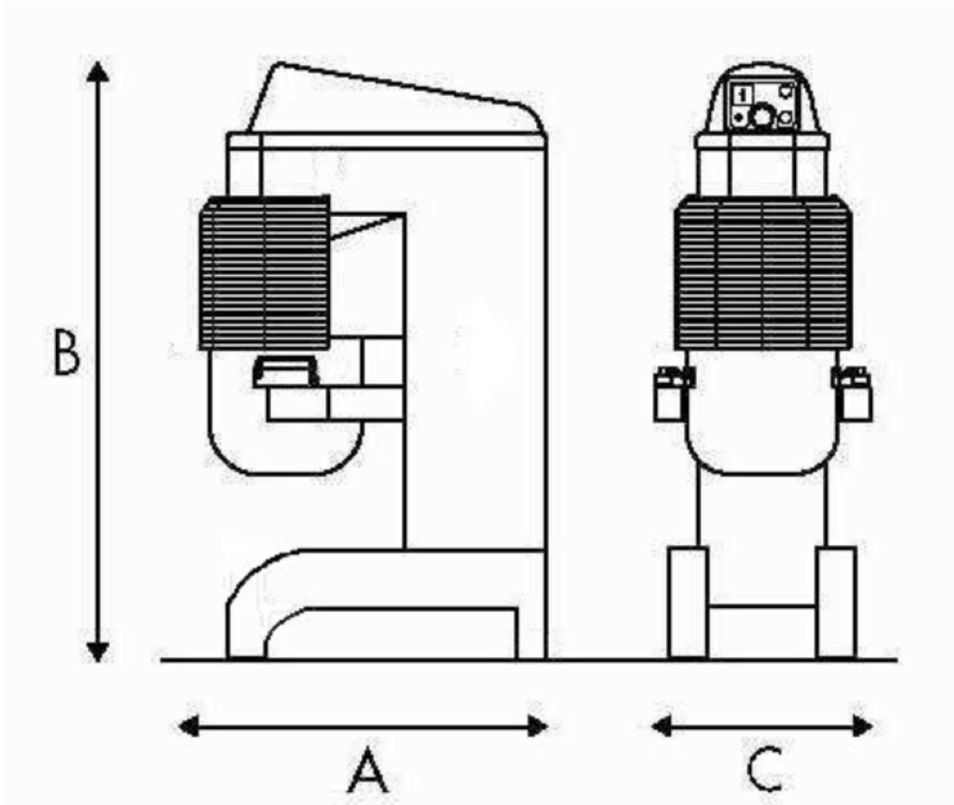

### SPECIFICATIONS

This is a very versatile machinery used as Mixer to whip Eggs or Cream and partially as Dough Mixer. Ideal for little spaces. It is manufactured in high quality and rugged materials. Thanks to the tool particular form and to its planetary rotating and eccentric movement, the mixer can whip and mix in short time a maximum volume of 40lt with an optimal homogeneity and oxygenation. Manual bowl uplift on slides by mean of leverage. The transmission system is particularly noiseless because every part is on rolling bearings. The machinery has three motor speeds and it is provided of the necessary safety devices.

### TECHNICAL FEATURES

#### DIMENSIONS

Ext. depth (A)	910mm
Ext. height (B)	1520mm
Ext. width (C)	650mm
Weight	250kg

#### SHIPMENT INFORMATION

Packed machinery:	
Max depth	1010mm
Max height	1730mm
Max width	750mm
Weight	(250+45)kg

#### FEEDING AND POWER

<i>Standard feeding</i>	
A.C. V400 3 50Hz (60Hz opt.)	
<i>Feeding on request</i>	
A.C. V230 3 50Hz (60Hz opt.)	

#### BOWL CAPACITY

Capacity (volume)	40lt
Bowl internal feed	400mm
Bowl internal height	380mm

Max power 1,3kW