

HB2R

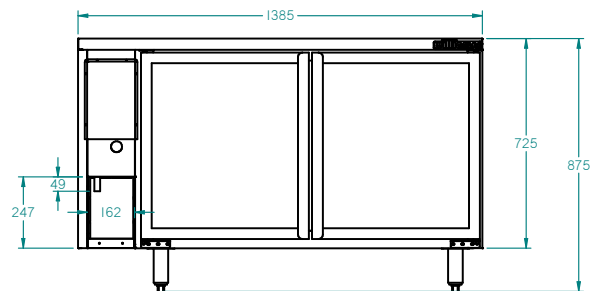

CATEGORY	GENERAL COUNTERS & BACK BARS
RANGE	Boronia
UNIT	REFRIGERATOR
TYPE	REMOTE
DOORS	2

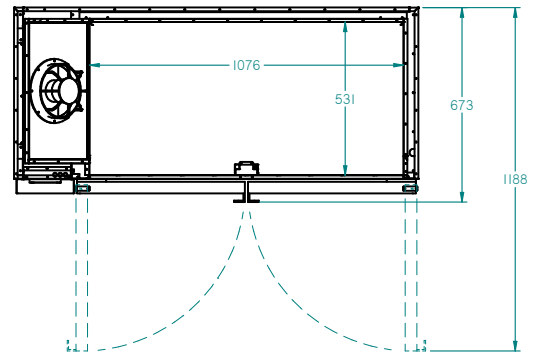
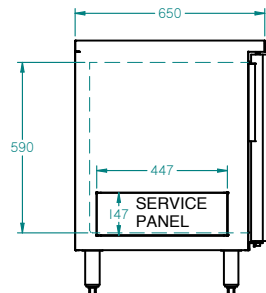
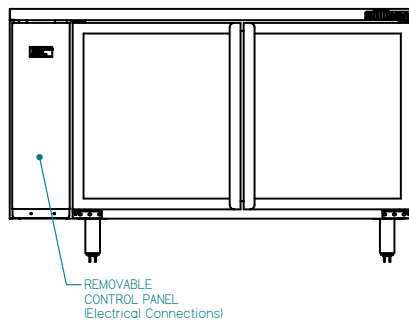

SPECIFICATIONS

CAPACITY LITRES	360
TEMPERATURE	1°C / 4°C
DIMENSIONS - W X D X H (ON LEGS) MM	1385 W x 650 D x 875 H
WEIGHT UNPACKED (KG)	120

STANDARD INCLUSIONS ***

DOOR TYPE	Standard: GD (Glass Door) Optional: SD (Solid Door)
FINISH	CBB (Black with stainless steel countertop and internal floor) or SS (Stainless Steel) interior and exterior excluding rear and under
SHELVES/DOOR	2

ELECTRICAL

POWER SUPPLY	10 amp	
FRIDGE MODELS	RUNNING AMPS	0.6

GAS TYPE

REFRIGERANT	R404a
REFRIGERATION WATTAGES FOR REMOTE UNITS	
REMOTE WATTAGES	560 @ -5°C SST

*** For **OPTIONS** refer to the current Williams Price Guide