



POTATO PEELER PI-30 230/50/1

Stainless steel construction commercial potato peeler. 30 Kg. / 66 pounds load per cycle.



P/N 1000631



DYNAMIC PREPARATION
COMMERCIAL POTATO PEELERS

SALES DESCRIPTION

Not only to peel potatoes, but also suitable to peel carrots and other similar products.

High capacity and production owing to lateral stirrers covered with silicon carbide abrasive (approved by NSF). Aluminium base plate lined with silicon carbide abrasive (approved by NSF). Construction in stainless steel.

- ✓ Auto-drag of waste to the drain.
- ✓ Energy efficiency thanks to engine optimisation.
- ✓ Lifiable transparent polycarbonate cover, complete with locking and safety device.
- ✓ Aluminium door with hermetic seal and safety device.
- ✓ Waterproof control board (IP65): Improved reliability against moisture and water splash.
- ✓ Water inlet system with non-return air break.
- ✓ Auxiliary contact for external electric valve.
- ✓ 0-6min timer and possibility of continuous operation.

ACCESSORIES

- Stands for potato peelers
- Filters for potato peelers



sammic | www.sammic.com
Food Service Equipment Manufacturer

Polígono Basarte, 1. phone +34 943 15 72 36
20720 Azkoitia, Spain sales@sammic.com



Project	Date
Item	Qty
Approved	

product sheet
updated 18/06/2021



POTATO PEELER PI-30 230/50/1

Stainless steel construction commercial potato peeler. 30 Kg. / 66 pounds load per cycle.



P/N 1000631

SPECIFICATIONS

Hourly production: 600 Kg / 720 Kg
Capacity per load: 30 Kg
Timer (min-max): 0' - 6'
Total loading: 730 W
Electrical supply: 230 V / 50 Hz / 1 ~ (4.6 A)
Plug: -

External dimensions (WxDxH)

- ✓ Width: 622 mm
- ✓ Depth: 760 mm
- ✓ Height: 1002 mm

External dimensions with stand

- ✓ Width with stand: 546 mm
- ✓ Depth with stand: 760 mm
- ✓ Height with stand: 1255 mm

Net weight: 61 Kg

Crated dimensions

670 x 835 x 1180 mm
Gross weight: 71.3 Kg.

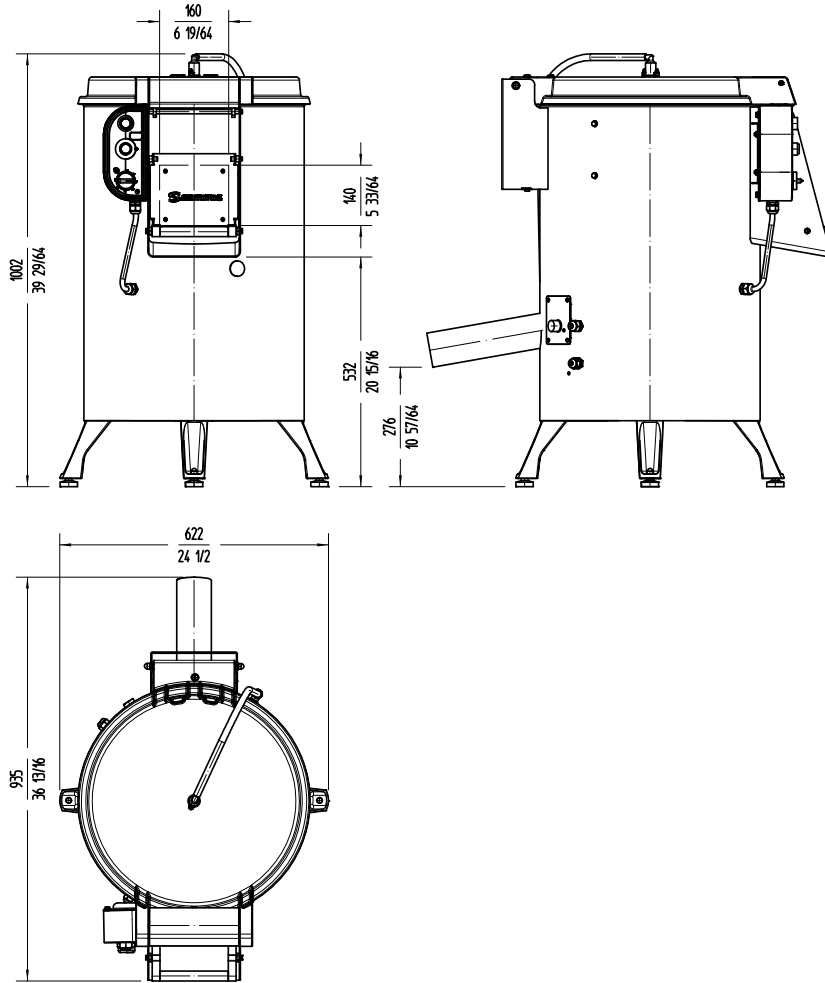

DYNAMIC PREPARATION
COMMERCIAL POTATO PEELERS

sammic | www.sammic.com
Food Service Equipment Manufacturer

Polígono Basarte, 1. phone +34 943 15 72 36
20720 Azkoitia, Spain sales@sammic.com



Project	Date
Item	Qty
Approved	

product sheet
updated 18/06/2021