

ProSpec

SKOPE Top Mount Freezer
Hydrocarbon



ProSpec
SKOPE Top Mount Freezer
Hydrocarbon
Service Manual

MAN80368
Rev. 1.1 Dec. 2022

© 2022 SKOPE Industries Limited. All rights reserved.

SKOPE Industries Limited reserves the right to alter specifications without notice.

SKOPE® is a registered trademark of SKOPE Industries Limited.
SKOPE INDUSTRIES LIMITED

Head Office
PO Box 1091, Christchurch
New Zealand
A.B.N. 73 374 418 306
AU: 1800 121 535
NZ: 0800 947 5673
E-mail: skope@skope.com
Website: www.skope.com

Trademark Infringement

The SKOPE trademark on this product is infringed if the owner, for the time being, does any of the following:

- Applies the trade mark to the product after its state, condition, get-up or packaging has been altered in any manner
- Alters, removes (including part removal) or obliterates (including part obliteration) the trade mark on the product
- Applies any other trade mark to the product
- Adds to the product any written material that is likely to damage the reputation of the trade mark

Notice of the above contractual obligations passes to:

- Successors or assignees of the buyer
- Future owners of the product

Contents

1 Servicing Hydrocarbon	
Overview	5
SKOPE Hydrocarbon Service Requirements	6
2 Specifications	
Models	7
3 Electronic Controller	
Overview	8
Apps	8
SCS Connect Field App	8
SCS Connect Track App	8
SKOPE-connect App	8
Controller Faceplate	9
Buttons and Display	9
Service Mode	9
SCS Connect Field App	10
Connecting	10
App Menu Items	11
Faults and Alarms	12
4 Wiring	
Model: ProSpec 1-door Freezer	19
Model: ProSpec 2-door Freezer	20
5 Spare Parts	
Main Assembly – 1-door Freezer	22
Main Assembly – 2-door Freezer	23
Cabinet Assembly – 1-door Cabinet	24
Cabinet Assembly – 2-door Cabinet	25
Solid Door Assembly	26
Front Panel Assembly	27
1-door Freezer Cartridge Assembly	28
2-door Freezer Cartridge Assembly	30
Electronic Controller Assembly	32
Electrics Junction Box Assembly	33
6 Installation	
Installation Guidelines	34
Ventilation Requirements	34
Shelves	35
Shelf Support Strips	35
Repositioning Shelves	36
7 Operation	
Loading Product	37
Light Switch	37
Refrigeration Cartridge Type Overview	38
Hot Gas Defrost	38
Refrigeration System Diagnostics – Function Test 1-Door Freezer	39
Compressor and Inverter Information	41
Inverter LED Indication	41
Trouble-shooting	41
Compressor	41

Compressor Inverter	42
Refrigeration System Diagnostics – Function Test 2-Door Freezer	43
Compressor	44
Compressor Electrical Supply Box	44
Compressor Connections	45
Crankcase Pressure Regulator	45
8 Replacement Procedures	
Refrigeration System	46
Before Servicing	46
On-site Work	47
Off-site Work	47
Refrigeration Cartridge Assembly	47
Not Cooling Fault	48
Removing the Cartridge	48
Replacing the Cartridge	49
Cartridge Electrics Box Assembly	49
Cartridge Cover Label	51
Cartridge Cover	51
Condenser Fan	51
Evaporator Fan	53
Replacing the Controller	54
Door Switch	55
Control Probe	56
Evaporator Probe	56
Condenser Probe	57
Ambient Probe	58
Replacing Component Notes	59
Disconnect the Cabinet from the Power Supply	59
Lighting	60
Doors	63
Alignment Adjustment	63
Replacing the Gasket	63
Removing and Refitting the Door	63
Replacing the Capstan	64
Cleaning	65
Cabinet	65
Condenser Coil	65
9 Troubleshooting	
Electronic Controller	66
Cabinet and Refrigeration Cartridge	66
Probe Resistance	69
On-site work Procedure	71

1 Servicing Hydrocarbon

Overview

This cabinet uses hydrocarbon (HC) R290 as its refrigerant. R290 is a natural refrigerant that has a very low environmental impact.

Special service requirements are needed, as R290 is a flammable refrigerant.

Safety hazards



The main hydrocarbon safety hazards are:

- Flammability
- Venting of hydrocarbon and compressor oil
- Asphyxiation

Service requirements

Do not interfere with the refrigeration system. All refrigeration maintenance and repairs must be undertaken according to the SKOPE HC Service Requirements. See the “SKOPE HC Service Requirements” below for more information, including examples of hazardous activities.

Electrical safety precautions

Correct wiring routing is as important as using correct components for compliance with safety and radio interference regulations. In order to maintain safety and compliance with regulations, any wiring that is disturbed during servicing must be replaced and secured in its original position.

SKOPE Hydrocarbon Service Requirements

Servicing must only be performed by approved SKOPE Service Technicians, and must meet all requirements in the SKOPE Hydrocarbon (HC) Service Policy (available from SKOPE), including the following:

Hydrocarbon work – SKOPE Service Policy

It is the responsibility of the service technician to follow SKOPE's Hydrocarbon equipment service policy and by accepting a service work order they agree to the following (where applicable):

- MUST – Ensure all workers are trained in the SAFETY of hydrocarbon products to the appropriate level for the work required.
- MUST – Follow all Local Safety Regulations relevant to flammable refrigerant gases.
 - Australia should reference - AIRAH Flammable Refrigerants – Safety Guide
 - New Zealand should reference – Flammable Refrigerant Safety Documentation (Refrigerant License NZ)
- MUST – Adhere to all on-site (workplace) Health and Safety requirements
- MUST – Not modify or alter the design of SKOPE equipment in any way
- MUST – In cases where the refrigeration system is not readily removable from the cabinet; then the entire cabinet MUST be sent to the Hydrocarbon workshop for repair.
- MUST – ONLY use SKOPE OEM Spare Parts; or identical replacement parts. Any variation in replacement part may render the system non-compliant and unsafe.
- MUST – Follow all best practice work activities for servicing hydrocarbon refrigerants (SKOPE recommend attending specific hydrocarbon refrigeration handling training courses). Nitrogen must be used for purging system before commencing “Hot Work” – brazing.
- MUST – Adhere to relevant SKOPE Service Manual. If any contradiction, the local Regulations take precedence over SKOPE requirements
- MUST – Work only in suitable, safe and compliant work spaces. Personal Protective Equipment must always be used when working on Hydrocarbon equipment.
- MUST – Service people diagnosing refrigeration faults must always carry and utilise Flammable Gas detectors when working on Hydrocarbon equipment.
- MUST – Prior to any service work; know where and how to safely and quickly isolate power supply to cabinet
- MUST – Not perform any Hot Work (brazing etc.) in the field. These are to be completed in a suitable service depot / workshop (in a dedicated specific Hazardous Work Area compliant to local flammable gas regulations)
- MUST – Not transport a refrigeration system with a known active leak. If there is an active leak the refrigerant must be safely removed (with use of Bullet Piercing Valve or Line Tap valves) before transporting. Valves must be removed at the hydrocarbon service depot once repair is completed.
- MUST – All hydrocarbon workshop areas must have emergency plans; that includes suitable evacuation and fire control plans and equipment.
- MUST – Only use refrigerant grade hydrocarbon, to precise mass specified on removable refrigeration system serial label.
- MUST – Be accurate refrigerant charge; The refrigerant mass is ultra-low charge and must only be measured in by accurate scales to +/- 1.0gram. Refrigerant MUST not be overcharged; or added to an already charged system.
- MUST – Use identical drier replacement; as any change will affect gas charge volume; and effect reliability compliance and safety.
- MUST – Any pipework replacement, must be identical to genuine SKOPE parts.
- MUST – Not introduce a sparking device inside a cabinet or inside a removable refrigeration system. Battery drills should not be used.
- MUST – Not perform any activity that could stress a refrigeration pipe (unless in a workshop).
- MUST – Get customer authorisation to permanently swap a removable refrigeration system.
- MUST – Have the Wellington Drive SCS Field app installed on a Bluetooth enabled device carried by the service technician (exception is for cabinets that do not utilise the Wellington Drive Controller).
The app should be utilised for safe, accurate diagnosis of the system and it is required to complete a controller replacement in the field.
- RECOMMENDED – Have the Wellington Drive SCS Track app installed on a Bluetooth enabled device carried by the service technician. This passive app collects system data from the Wellington Drive SCS Connect Controller and transmit it to the cloud.
- Logistics companies may be used to transport a complete refrigerator where no separation of the refrigeration system occurs. Logistics companies are not required to be contracted to this SKOPE Service Policy.

2 Specifications

Models

This product service manual is applicable to the SKOPE ProSpec top mount upright freezers detailed in the table below. Refer to the relevant product specification sheet (available on the SKOPE website: www.skope.com) for specifications.

Table 1: Model sepecifications

Series	Model	SKOPE ID	Unit
ProSpec Freezer Series	PG21.UPF.1.SD	PP1F	UTHDNI-0043
	PG21.UPF.2.SD	PP2F	UTHDNI-0051

3 Electronic Controller

Overview

The product is fitted with a Wellington Drive SCS Connect electronic controller. The controller is located above the door/s and visible from the outside of the cabinet.

Controller servicing can be performed via the controller faceplate, or the SCS Connect Field app.

This does not control the cabinet body and door heater elements

Apps

SCS Connect Field App The SCS Connect Field app is designed for service techs, and provides access to the controller from mobile devices with Bluetooth capability. The app provides information on data logging, alarm notification and diagnostic control.

See “SCS Connect Field App” on page 10 for information on setting up and using the app.

SCS Connect Track App The SCS Connect Track app is used to upload data from cabinets fitted with a Wellington SCS Connect electronic controller.

SKOPE-connect App The SKOPE-connect app is designed for end-users and provides wireless access to the controller from mobile devices with Bluetooth capability.

The app allows end users to adjust some electronic controller settings including energy saving modes, open/close hours and preset temperature set points for specific product.

The app may be useful for diagnostics. Download from the Google Play Store, or Apple App Store.



Apple App store



Google Play store

Controller Faceplate

Buttons and Display The faceplate includes the front display panel and interface buttons.

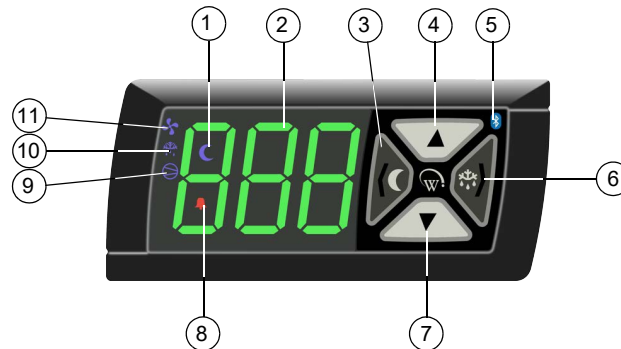

Table 2: Controller faceplate

No.	Description			Use
1	Night Mode	Indicator	On during night mode.	
2	Display	Indicator	Digital display of: <ul style="list-style-type: none"> the cabinet's air (not product) temperature. alarm messages. 	
3	Light Switch - Night Mode (back/abort)	Button	Used during programming.	Press to switch the lights on or off. Press and hold to switch the Freezer between Day and Night modes.
4	Up	Button	Used during programming.	
5	Bluetooth	Indicator	On when ready to connect to a device. Flashing when connected to a device.	
6	Defrost Cycle (next/enter)	Button	Used during programming.	Press and hold to start a manual defrost.
7	Down	Button	Used during programming.	
8	Fault - Alarm	Indicator	On during a fault or alarm.	
9	Compressor	Indicator	On when the compressor is running.	
10	Defrost Mode	Indicator	On during the defrost cycle.	
11	Fan	Indicator	On when the fans are running.	

Service Mode Service mode can be accessed and used via the SCS Connect Field app (see “SCS Connect Field App” on page 10), or the controller faceplate (see below).

Note: A 9-digit pin code is required to access service mode via the controller buttons. Contact your User Manager to receive your activation code.

Procedure 1: To enable and use service mode via the controller faceplate

1. Press and hold the up and down buttons simultaneously until prompted to enter the 9 digit pin code.
2. Enter service mode pin code.
3. Use the up, down, back/abort and next/enter buttons to navigate to the desired category.

There are 5 main service mode categories when accessing and using service mode via the controller faceplate:

Parameters

Provides access and editing of individual controller parameters.

It is not recommended that parameters are changed unless absolutely necessary. If incorrect parameter settings are suspected, reload the complete parameter set.

Reset

Returns the controller back to factory settings. Parameter set must be reloaded after performing a reset.

Manual test

Allows inspection of input values from sensors, and check the effects of output adjustments to peripherals, and to run preset test routines.

Statistics

Displays logged values and event counts to assist with fine tuning and diagnostics.

About

Lists the properties of the refrigeration system and the controller, including cooler model codes, firmware, hardware and software versions.

SCS Connect Field App

Connecting The SCS Connect Field app gives authorised service technicians wireless access to the controller from mobile devices with Bluetooth capability. The app provides data logging, alarm notification, and control over inputs (probes, switches) and outputs (e.g. relays).

Procedure 2: To install the SCS Connect Field app

Before you start

When you first run the app, you will need to enter an activation code – a 9-digit PIN. If you don't already have one, contact SKOPE Customer Services to request an activation code. You will need to be connected to the internet at the time of activation.

Your activation code is unique to you, and determines your personal level of access for the app. **Never** share it with anyone else. The same code will give you access to all SCS apps you are authorised to use.

1. Download and install the Connect Field app:

- Apple App Store:
<https://apps.apple.com/nz/app/scs-connect-field/id1172570106>



- Google Play Store:
<https://play.google.com/store/apps/details?id=air.com.wdtl.scs.diagnostic.mobile>



-
2. Make sure you are connected to the internet, and enter your 9-digit activation code.
3. Once activation is complete, you must define a 4-digit PIN. This can be any code unique to you. Each time you start the app, you will be required to enter this same PIN. This is to prevent other people accessing the app from an unlocked phone.
-
-

Procedure 3: To connect to a controller

1. Check that the Bluetooth logo on the top right of the controller faceplate is unlit, indicating that the controller is ready to connect to a device.
Note: A flashing Bluetooth logo indicates that the controller is currently connected to a device.
2. Open the SCS Connect Field app.
3. Select the controller from the list of visible controllers.
Note: This list is filtered by your activation permissions, so devices you are not authorised to connect to will not be displayed.
4. Select "CONNECT" to connect to the controller.
5. Check that the Bluetooth logo on the top right of the controller faceplate is flashing, indicating that the controller is connected.

App Menu Items You can find information and make changes to the connected controller and its fridge via the app menu.

Home screen

Shows a graphic representation of the fridge being controlled.

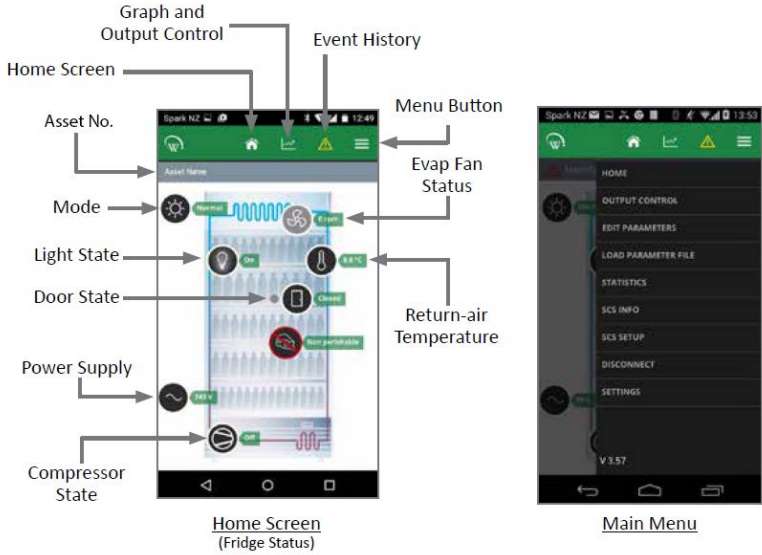

Table 3: SCS Connect Field App Home Screen

Item	Description	Action
Output control	Gives you control of the input sensors and switches, and output relays.	
Edit parameters	Allows you to access and edit individual controller parameters. SKOPE does not recommended changing parameters unless absolutely necessary.	If you edit a parameter, you must: <ul style="list-style-type: none"> • select "DISCONNECT" from the menu to apply the updated parameter. • record the changes on the warranty/job card.
Load parameter file	Allows you to reload a default parameter set or change to new parameter set. SKOPE does not recommended changing parameters unless absolutely necessary.	<ol style="list-style-type: none"> 1. If you suspect an incorrect parameter setting, reload the complete parameter set. 2. After loading the new parameter set, select "DISCONNECT" from the menu to apply the updated parameters.
Statistics	Displays information from the past seven days about the fridge's activity, including temperatures, door openings and alarms.	
SCS info	Displays information about the cabinet and the controller version.	
SCS setup	Allows you to add or change SCS info (see above).	

Table 3: SCS Connect Field App Home Screen (continued)

Item	Description	Action
Disconnect	Allows you to disconnect from the currently connected controller.	
Settings	Allows you to change the app's general settings and see which databases you have activated. You can have more than one database activated at the same time.	To add a new database, select ACTIVATE ANOTHER DATABASE, and enter the new database's unique activation code.

Table 4: ProSpec parameter numbers

Model	Parameter number	
ProSpec Freezer Series	PG21.UPF.1.SD	629
	PG21.UPF.2.SD	630

Faults and Alarms

If a fault occurs, it is logged, the Fault - Alarm indicator is lit on the controller faceplate, and a message may be displayed. Faults do not affect product temperature, and do not require action from the shop owner, unless they turn into an alarm.

If an alarm occurs, it is logged, the Fault - Alarm indicator is lit, and the alarm message is displayed on the controller faceplate. Alarms may result in abnormal product temperature.

Some faults and alarms can be cleared by the shop owner, and others can only be cleared by a service technician. Faults and alarms can be cleared by the shop owner by power-cycling the cabinet. However the fault or alarm will only clear if the problem has been fixed. If the problem still exists after a power-cycle, a service technician will need to fix the problem.

Table 5: Faults

Description	Possible root cause	Actions
Over-voltage protection The maximum allowable mains supply voltage has been exceeded. The cabinet has temporarily shut down to prevent damage and will restart once the supply voltage decreases.	Should be a one-off. If it continues, consider:	Test the incoming voltage to ensure it is correct. The test voltage needs to be between 198 and 264 volts.
	<ul style="list-style-type: none"> poor line voltage 	
	<ul style="list-style-type: none"> rural location 	<ul style="list-style-type: none"> Check the voltage parameter settings are between 198 and 264 volts. If this parameter is outside the correct voltage, changing it may damage the controller.
	<ul style="list-style-type: none"> voltage setting parameter 	
	<ul style="list-style-type: none"> controller 	

Table 5: Faults (continued)

Description	Possible root cause	Actions
<p>Under-voltage protection</p> <p>The mains supply voltage has dropped below the minimum allowable level. The cabinet has temporarily shut down to prevent damage and will restart once the supply voltage increases.</p>	<p>Should be a one-off. If continues, consider:</p> <ul style="list-style-type: none"> • power supply overloaded • poor line voltage • multi-box use • rural location • voltage setting parameter • controller 	<p>Test the incoming voltage to ensure it is correct. The test voltage needs to be between 198 and 264 volts.</p> <ul style="list-style-type: none"> • If outside this, the controller will shut the system down until the voltage returns to between these measurements. • If the voltage is correct and the controller is still showing a fault, replace the controller. • Check that there are not too many plugs using the same multi-box adaptor causing the voltage to drop. • Check the voltage parameter settings are between 198 and 264 volts. If this parameter is outside the correct voltage, changing it may damage the controller. • The controller may be reading incorrectly and need replacing.
<p>High condensing temperature protection</p> <p>The system was operating at an elevated temperature and has temporarily shut down to prevent damage. Extended operation in this condition may result in ALARM 15, increased energy consumption and a reduction in cabinet life.</p>	<ul style="list-style-type: none"> • Condenser not clean • Poor installation or ventilation • Condenser fan motor or blade • Controller • Very high ambient temperature 	<p>Cartridge swap is not required.</p> <ul style="list-style-type: none"> • Remove and clean the condenser filter. • Check that the condenser is free of debris. • If the coil is dirty, clean it with a vacuum cleaner or soft brush. • Check the installation guidelines. • If fitted, check the rear stand-offs are extended. • Check that the condenser fan blades are in place and all condenser fans are operating correctly. • The controller may be reading incorrectly and need replacing. • Confirm the temperature reading with an independent thermometer. • Check if the probes are faulty and reading incorrectly.

Table 5: Faults (continued)

Description	Possible root cause	Actions
<p>Excessive compressor cycling protection The system has been turning on and off too frequently.</p>	<ul style="list-style-type: none"> Door not self-closing 	<ul style="list-style-type: none"> Open the door and let it go. If it does not close on its own, repair the self-closing mechanism.
	<ul style="list-style-type: none"> Blocked condenser 	<ul style="list-style-type: none"> Remove and clean the condenser filter. Check that the condenser is free of debris. If the coil is dirty, clean it with a vacuum cleaner or soft brush.
	<ul style="list-style-type: none"> Poor installation or ventilation 	<ul style="list-style-type: none"> Check the installation guidelines.
	<ul style="list-style-type: none"> Cartridge or cabinet gasket seals leaking 	<ul style="list-style-type: none"> Remove the cartridge and check the integrity of the gaskets and seals. If required, replace the door gasket.
	<ul style="list-style-type: none"> Hot product 	<ul style="list-style-type: none"> Check if the product has been recently loaded, and is causing the extra heat.
	<ul style="list-style-type: none"> Product blocking cabinet airflow 	<ul style="list-style-type: none"> Check if the return air grille is covered by product. If so, move the product from the grille and observe.
	<ul style="list-style-type: none"> Compressor is overloaded from excess door openings or ambient temperature 	<ul style="list-style-type: none"> Ensure that the cabinet is operating in its climate class.
	<ul style="list-style-type: none"> Condenser or evaporator fan motor or blade 	<ul style="list-style-type: none"> Inspect the condenser and evaporator fans safely, and replace if faulty.
	<ul style="list-style-type: none"> Controller 	<ul style="list-style-type: none"> The controller may be reading incorrectly and need replacing.
<ul style="list-style-type: none"> Compressor or gas leak 	<ul style="list-style-type: none"> Swap the cartridge. 	

Table 6: Alarms

Code	Description	Possible root cause	Action
8	Estimated product temperature below allowable range	<ul style="list-style-type: none"> Low ambient temperature 	<ul style="list-style-type: none"> Ensure that the cabinet is operating in its climate class.
	The estimated product temperature has been below the allowable range for longer than the permissible time.	<ul style="list-style-type: none"> App settings 	<ul style="list-style-type: none"> Check all app settings, and reinstall the parameters if required.
		<ul style="list-style-type: none"> Controller 	<ul style="list-style-type: none"> Check the probe calibration to make sure that the controller is reading the temperature correctly.

Table 6: Alarms (continued)

Code	Description	Possible root cause	Action
9	<p>Estimated product temperature above allowable range</p> <p>The estimated product temperature has been above the allowable range for longer than the permissible time.</p>	<ul style="list-style-type: none"> Excessive door openings 	<ul style="list-style-type: none"> Make sure the door is not opened unnecessarily.
		<ul style="list-style-type: none"> Door being left open 	<ul style="list-style-type: none"> Ensure the door is closed.
		<ul style="list-style-type: none"> Door leaking air (bad gasket or door not self-closing) 	<ul style="list-style-type: none"> Open the door and let it go. If it does not close on its own, repair the self-closing mechanism. If required, replace the door gasket.
		<ul style="list-style-type: none"> Sealed refrigeration system 	<ul style="list-style-type: none"> Consider a cartridge swap.
		<ul style="list-style-type: none"> Incorrect setpoint 	<ul style="list-style-type: none"> Reload the correct parameters using the SCS Connect Field app.
		<ul style="list-style-type: none"> Too much product 	<ul style="list-style-type: none"> If the cabinet is overloaded, remove the excess product.
		<ul style="list-style-type: none"> Blocked return air grille 	<ul style="list-style-type: none"> Check if the return air grille is covered by product. If so, move the product from the grille and observe.
		<ul style="list-style-type: none"> Warm product loaded into cabinet 	
		<ul style="list-style-type: none"> Blocked condenser 	<ul style="list-style-type: none"> Remove and clean the condenser filter. Check that the condenser is free of debris. If the coil is dirty, clean it with a vacuum cleaner or soft brush.
		<ul style="list-style-type: none"> Poor installation or ventilation 	<ul style="list-style-type: none"> Check the installation guidelines.
		<ul style="list-style-type: none"> Frozen or blocked evaporator coil 	<ul style="list-style-type: none"> De-ice the coil and check that the evaporator fan motor is working. Check the defrost cycle and that the defrost probe are working correctly. Check that the drain is clear.
		<ul style="list-style-type: none"> Cartridge gasket leaking (to cabinet seal or lid seal) 	<ul style="list-style-type: none"> Check that the gasket is intact and not broken and leaking. Ensure the installation levers are lifting the cartridge up onto the case correctly.
		<ul style="list-style-type: none"> Compressor is overloaded from excess door openings or ambient temperature 	<ul style="list-style-type: none"> Ensure that the cabinet is operating in its climate class.
		<ul style="list-style-type: none"> Condenser or evaporator fan motor or blade 	<ul style="list-style-type: none"> Inspect the condenser and evaporator fans safely, and replace if faulty.
		<ul style="list-style-type: none"> Incorrect parameter settings 	<ul style="list-style-type: none"> Use the SCS Field app to check that the correct setpoint and parameters have been selected.
<ul style="list-style-type: none"> Controller 	<ul style="list-style-type: none"> Check the probe calibration to make sure that the controller is reading the temperature correctly. 		
<ul style="list-style-type: none"> Compressor or gas leak 	<ul style="list-style-type: none"> Swap the cartridge. 		
15	<p>Excessive condensing temperature protection</p> <p>The system was operating at an excessive temperature and has shut down to prevent permanent damage.</p>		<p>Cartridge swap is not required.</p>
		<ul style="list-style-type: none"> Very high ambient temperature 	<ul style="list-style-type: none"> Ensure that the cabinet is operating in its climate class.
		<ul style="list-style-type: none"> Condenser is not clean 	<ul style="list-style-type: none"> Remove and clean the condenser filter. Check that the condenser is free of debris. If the coil is dirty, clean it with a vacuum cleaner or soft brush.
		<ul style="list-style-type: none"> Poor installation or ventilation 	<ul style="list-style-type: none"> Check the installation guidelines.
		<ul style="list-style-type: none"> Condenser fan motor or blade 	<ul style="list-style-type: none"> Inspect the condenser and evaporator fans safely, and replace if faulty.
<ul style="list-style-type: none"> Incorrectly placed condenser probe 	<ul style="list-style-type: none"> Either: <ul style="list-style-type: none"> Measure the probe resistance to make sure it is within the range. Compare the probe's temperature with the known temperature, using an external trusted thermometer. Replace the probe if required. 		

Table 6: Alarms (continued)

Code	Description	Possible root cause	Action
17	Control probe failure A critical system sensor has failed and the cabinet can no longer operate.	<ul style="list-style-type: none"> Control probe or circuit 	Cartridge swap is not required. <ul style="list-style-type: none"> Either: <ul style="list-style-type: none"> Measure the probe resistance to make sure it is within the range. Compare the probe's temperature with the known temperature, using an external trusted thermometer. Replace the probe if required.
		<ul style="list-style-type: none"> Controller 	<ul style="list-style-type: none"> If you have replaced the probe and it is still reading incorrectly, replace the controller.
18	Electrical over-current protection activated The compressor was drawing too much current and has shut down to prevent permanent damage.	<ul style="list-style-type: none"> Blocked condenser 	<ul style="list-style-type: none"> Remove and clean the condenser filter. Check that the condenser is free of debris. If the coil is dirty, clean it with a vacuum cleaner or soft brush.
		<ul style="list-style-type: none"> Product blocking cabinet airflow 	<ul style="list-style-type: none"> Check if the return air grille is covered by product. If so, move the product from the grille and observe.
		<ul style="list-style-type: none"> Compressor is overloaded from excess door openings or ambient temperature 	<ul style="list-style-type: none"> Ensure that the cabinet is operating in its climate class.
		<ul style="list-style-type: none"> Compressor or gas leak 	<ul style="list-style-type: none"> Swap the cartridge.
19	Failed to reach set temperature The refrigeration system has been operating continuously for a long period without reaching the set temperature.	<ul style="list-style-type: none"> Blocked condenser 	<ul style="list-style-type: none"> Remove and clean the condenser filter. Check that the condenser is free of debris. If the coil is dirty, clean it with a vacuum cleaner or soft brush.
		<ul style="list-style-type: none"> Poor installation or ventilation 	<ul style="list-style-type: none"> Check the installation guidelines.
		<ul style="list-style-type: none"> Frozen or blocked evaporator coil 	<ul style="list-style-type: none"> De-ice the coil and check that the evaporator fan motor is working. Check the defrost cycle and that the defrost probe is working correctly.
		<ul style="list-style-type: none"> Cartridge, cabinet, or door gasket leaking 	<ul style="list-style-type: none"> Check that the gasket is intact and not broken and leaking. If required, replace the door gasket. Ensure the installation levers are lifting the cartridge up onto the case correctly.
		<ul style="list-style-type: none"> Product blocking cabinet airflow 	<ul style="list-style-type: none"> Check if the return air grille is covered by product. If so, move the product from the grille and observe.
		<ul style="list-style-type: none"> Compressor is overloaded from excess door openings or ambient temperature 	<ul style="list-style-type: none"> Ensure that the cabinet is operating in its climate class.
		<ul style="list-style-type: none"> Condenser or evaporator fan motor or blade 	<ul style="list-style-type: none"> Inspect the condenser and evaporator fans safely, and replace if faulty.
		<ul style="list-style-type: none"> Controller 	<ul style="list-style-type: none"> The controller may be reading incorrectly and need replacing.
20	Over-cooling product The internal temperature is too low. The system has temporarily shut down until the temperature has returned to normal.	<ul style="list-style-type: none"> Set temperature has been raised by a large amount 	<ol style="list-style-type: none"> Confirm if really too cold. Change parameters accordingly.
		<ul style="list-style-type: none"> Controller 	<ul style="list-style-type: none"> The controller may be reading incorrectly and need replacing.
22	Evaporator fan over-current protection The current supplied to the evaporator fan motor is too high.	<ul style="list-style-type: none"> Faulty fan motor 	<ul style="list-style-type: none"> Replace the fan motor.
		<ul style="list-style-type: none"> Fan blade fault (imbalance, debris, blockage) 	<ul style="list-style-type: none"> Visually inspect the fan blades and replace if faulty.

Table 6: Alarms (continued)

Code	Description	Possible root cause	Action
23	Condenser fan over-current protection The current supplied to the condenser fan motor is too high.	• Faulty fan motor	• Replace fan motor.
		• Fan blade fault (imbalance, debris, blockage)	• If the fan motor is working correctly, update the controller firmware to the latest version.
		• Controller	• The controller may be reading incorrectly and need replacing.
24	Controller communication error Controller has lost communication channels.	• Parameters	• Load the correct parameter settings.
		• Controller or circuit	• The controller may be reading incorrectly and need replacing.
25	Controller update failed Controller update could not be completed.	• Parameters	• Load the correct parameter settings.
		• Controller or circuit	• The controller may be reading incorrectly and need replacing.
26	Controller hardware failure Controller hardware has failed.	• Parameters	• Load the correct parameter settings.
		• Controller or circuit	• Replace the controller.
27	Probe failure A probe other than the control probe has failed. The cabinet will continue to operate with partial function but requires service.	• Evaporator probe or connections	Cartridge swap is not required. • Either: • Measure the probe resistance to make sure it is within the range. • Compare the probe's temperature with the known temperature, using an external trusted thermometer. • Replace the probe if required.
		• Controller	• The controller may be reading incorrectly and need replacing.
28	No downward tendency The temperature is no longer decreasing.	• Blocked condenser	• Remove and clean the condenser filter. • Check that the condenser is free of debris. • If the coil is dirty, clean it with a vacuum cleaner or soft brush.
		• Poor installation or ventilation	• Check the installation guidelines.
		• Cartridge or cabinet gasket seals leaking	• Check that the gasket is intact and not broken and leaking. If required, replace the door gasket. • Ensure the installation levers are lifting the cartridge up onto the case correctly.
		• Door not self-closing or door gasket leaking	• Open the door and let it go. If it does not close on its own, repair the self-closing mechanism. • If required, replace the door gasket.
		• Product blocking cabinet airflow	• Check if the return air grille is covered by product. If so, move the product from the grille and observe.
		• Compressor is overloaded from excess door openings or ambient temperature	• Ensure that the cabinet is operating in its climate class.
		• Condenser or evaporator fan motor or blade	• Inspect the condenser and evaporator fans safely, and replace if faulty.
		• Controller	• The controller may be reading incorrectly and need replacing.
		• Compressor or gas leak	• Swap the cartridge.

Table 6: Alarms (continued)

Code	Description	Possible root cause	Action
30	Excessive automatic defrosting The system is automatically defrosting too frequently.	<ul style="list-style-type: none"> Door not self-closing or door gasket leaking 	<ul style="list-style-type: none"> Open the door and let it go. If it does not close on its own, repair the self-closing mechanism. If required, replace the door gasket.
		<ul style="list-style-type: none"> Evaporator probe 	Either: <ul style="list-style-type: none"> Measure the probe resistance to make sure it is within the range. Compare the probe's temperature with the known temperature, using an external trusted thermometer.
		<ul style="list-style-type: none"> Evaporator motor or fan 	<ul style="list-style-type: none"> Check that the fan motors are working and the fan blades are not damaged.
		<ul style="list-style-type: none"> Controller 	<ul style="list-style-type: none"> The controller may be reading incorrectly and need replacing.
		<ul style="list-style-type: none"> Blocked drain 	<ul style="list-style-type: none"> Clear the blockage with a wet vacuum. Clear the debris to prevent a blockage.
		<ul style="list-style-type: none"> Defrost setting too high 	<ul style="list-style-type: none"> Reload the correct parameters using the SCS Connect Field app.
		<ul style="list-style-type: none"> Compressor or gas leak 	<ul style="list-style-type: none"> Swap the cartridge.

4 Wiring

Model: ProSpec 1-door Freezer

Model Number: PG21.UPF.1.SD

WIRE COLOURS

BK	Black
BN	Brown
RD	Red
OG	Orange
GN	Green
BU	Blue
GY	Grey
WH	White
GNYE	Green-Yellow
Based upon IEC 757 Standard	

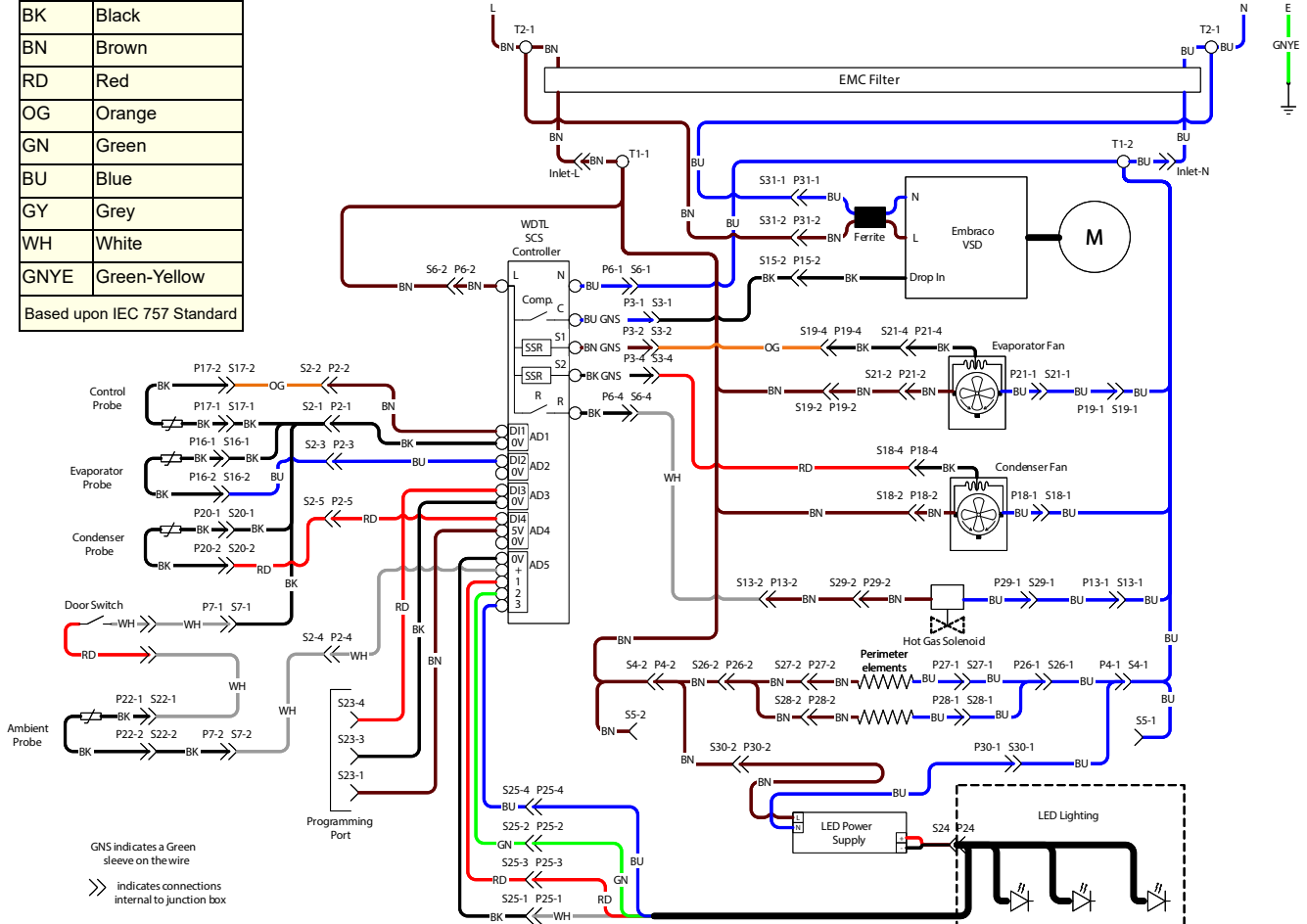

LEGEND

Internal Unit Junction Box Sockets/Plugs		S17/P17	Cabinet Sensor Socket/Plug (Blue 2-way)
Inlet	IEC Cabinet Socket/Plug	S18/P18	Condenser Motor Unit Socket/Plug (Red 4-way)
S1/P1	Not Used	S19/P19	Evaporator Motor Unit Socket/Plug (White 4-way)
S2/P2	Unit Junction Box to Controller Signal Socket/Plug (6-way)	S20/P20	Condenser Sensor Socket/Plug (Red 2-way)
S3/P3	Unit Junction Box to Controller Power Socket/Plug (Blue 4-way)	T1	Unit Terminals
S4/P4	Lighting/Heater Wire Unit Socket/Plug (Black 3-way)	T2	EMI Filter Box Terminals
S5	Lighting/Heater Wire Unit Socket (Black 3-way) (unused)	External Sockets/Plugs	
S6/P6	Unit Junction Box to Controller Power Socket/Plug (Red 4-way)	S21/P21	Evaporator Motor Extension Socket/Plug (Red 4-way)
S7/P7	Door Sensor Socket/Plug (White 2-way)	S22/P22	Ambient Sensor Socket/Plug (White 2-way)
S8/P8	Not Used	S23/P23	Programming/Comms Port Socket (Blue 4-way)
S9/P9	Not Used	S24/P24	LED Driver DC Out Put Socket/Plug (Red 2-way)
S10/P10	Not Used	S25/P25	LED Lighting Loom Socket/Plug (White 6-way)
S11/P11	Not Used	S26/P26	Heater Socket/Plug 1 (Black 3-way)
S12/P12	Not Used	S27/P27	Heater Socket/Plug 2 (Black 2-way)
S13/P13	Hot Gas Solenoid Unit Socket/Plug (White 3-way)	S28/P28	Heater Socket/Plug 3 (Black 3-way)
S14/P14	Not Used	S29/P29	Hot Gas Solenoid Extension Socket/Plug (White 3-way to Molex)
S15/P15	Compressor Unit Socket/Plug (Blue 4-way)	S30/P30	LED Driver AC Extension FI ex Socket/Plug (White plugged into black 3-way)
S16/P16	Evaporator Sensor Socket/Plug (Black 2-way)	S31/P31	Unfiltered VSD Supply Socket/Plug (Yellow 4-way)

Model: ProSpec 2-door Freezer

Model Number: PG21.UPF.2.SD

WIRE COLOURS

BK	Black
BN	Brown
RD	Red
OG	Orange
GN	Green
BU	Blue
GY	Grey
WH	White
GNYE	Green-Yellow
Based upon IEC 757 Standard	

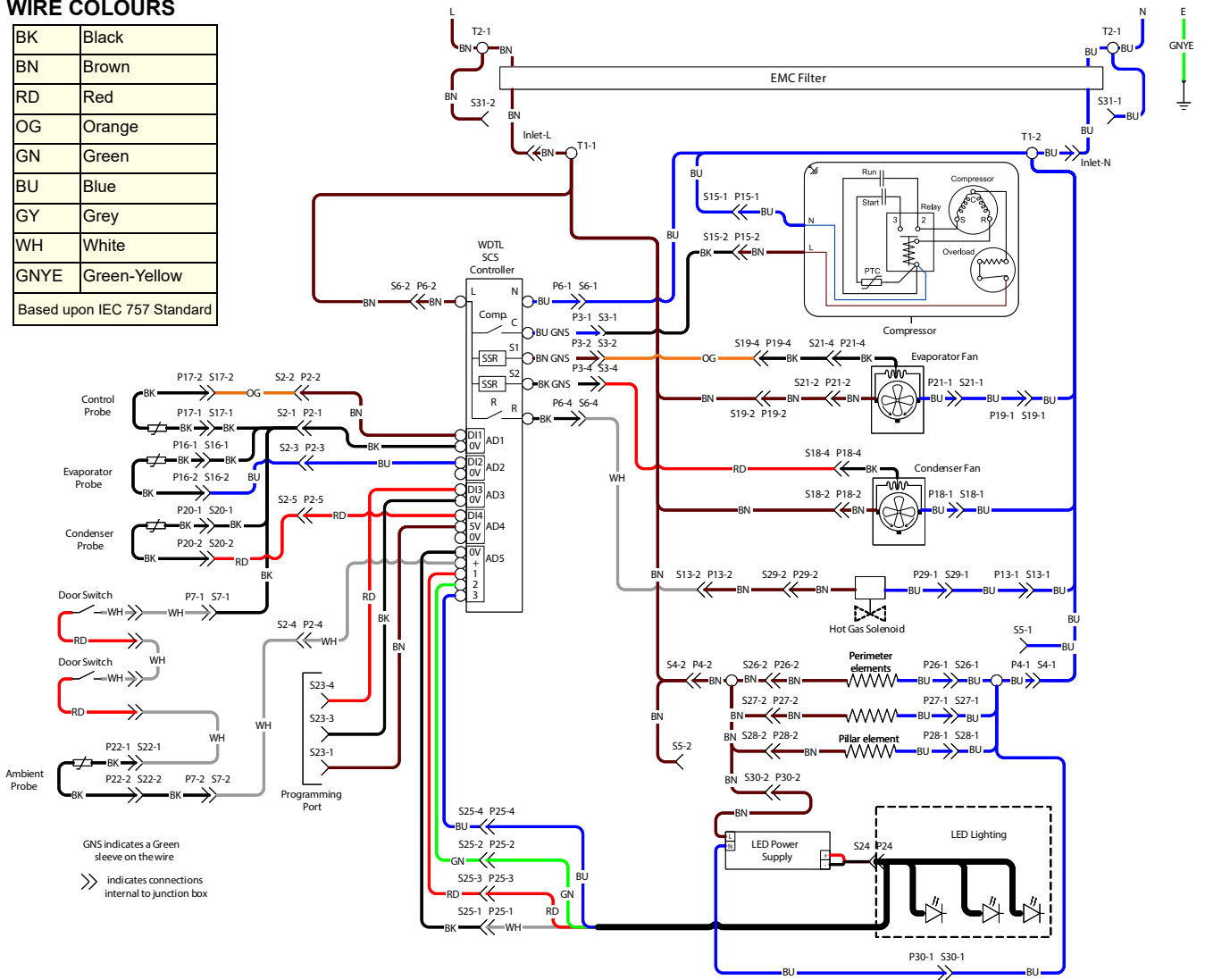

LEGEND

Internal Unit Junction Box Sockets/Plugs		S17/P17	Cabinet Sensor Socket/Plug (Blue 2-way)
Inlet	IEC Cabinet Socket/Plug	S18/P18	Condenser Motor Unit Socket/Plug (Red 4-way)
S1/P1	Not Used	S19/P19	Evaporator Motor Unit Socket/Plug (White 4-way)
S2/P2	Unit Junction Box to Controller Signal Socket/Plug (6-way)	S20/P20	Condenser Sensor Socket/Plug (Red 2-way)
S3/P3	Unit Junction Box to Controller Power Socket/Plug (Blue 4-way)	T1	Unit Terminals
S4/P4	Lighting/Heater Wire Unit Socket/Plug (Black 3-way)	T2	EMI Filter Box Terminals
S5	Lighting/Heater Wire Unit Socket (Black 3-way) (unused)	External Sockets/Plugs	
S6/P6	Unit Junction Box to Controller Power Socket/Plug (Red 4-way)	S21/P21	Evaporator Motor Extension Socket/Plug (Red 4-way)
S7/P7	Door Sensor Socket/Plug (White 2-way)	S22/P22	Ambient Sensor Socket/Plug (White 2-way)
S8/P8	Not Used	S23/P23	Programming/Comms Port Socket (Blue 4-way)
S9/P9	Not Used	S24/P24	LED Driver DC Out Put Socket/Plug (Red 2-way)
S10/P10	Not Used	S25/P25	LED Lighting Loom Socket/Plug (White 6-way)
S11/P11	Not Used	S26/P26	Heating Loom Socket/Plug 1 (Black 3-Way)
S12/P12	Not Used	S27/P27	Heating Loom Socket/Plug 2 (Black 3-Way)
S13/P13	Hot Gas Solenoid Unit Socket/Plug (White 3-way)	S28/P28	Heating Loom Socket/Plug 3 (Black 3-Way)
S14/P14	Not Used	S29/P29	Hot Gas Solenoid Extension Socket/Plug (White 3-way to Molex)
S15/P15	Compressor Unit Socket/Plug (Blue 4-way)	S30/P30	LED Driver AC Extension Flex Socket/Plug (White to black 3-way)
S16/P16	Evaporator Sensor Socket/Plug (Black 2-way)	S31/P31	Unfiltered Supply Socket (Yellow 4-way) (Unused)

5 Spare Parts

Main Assembly – 1-door Freezer

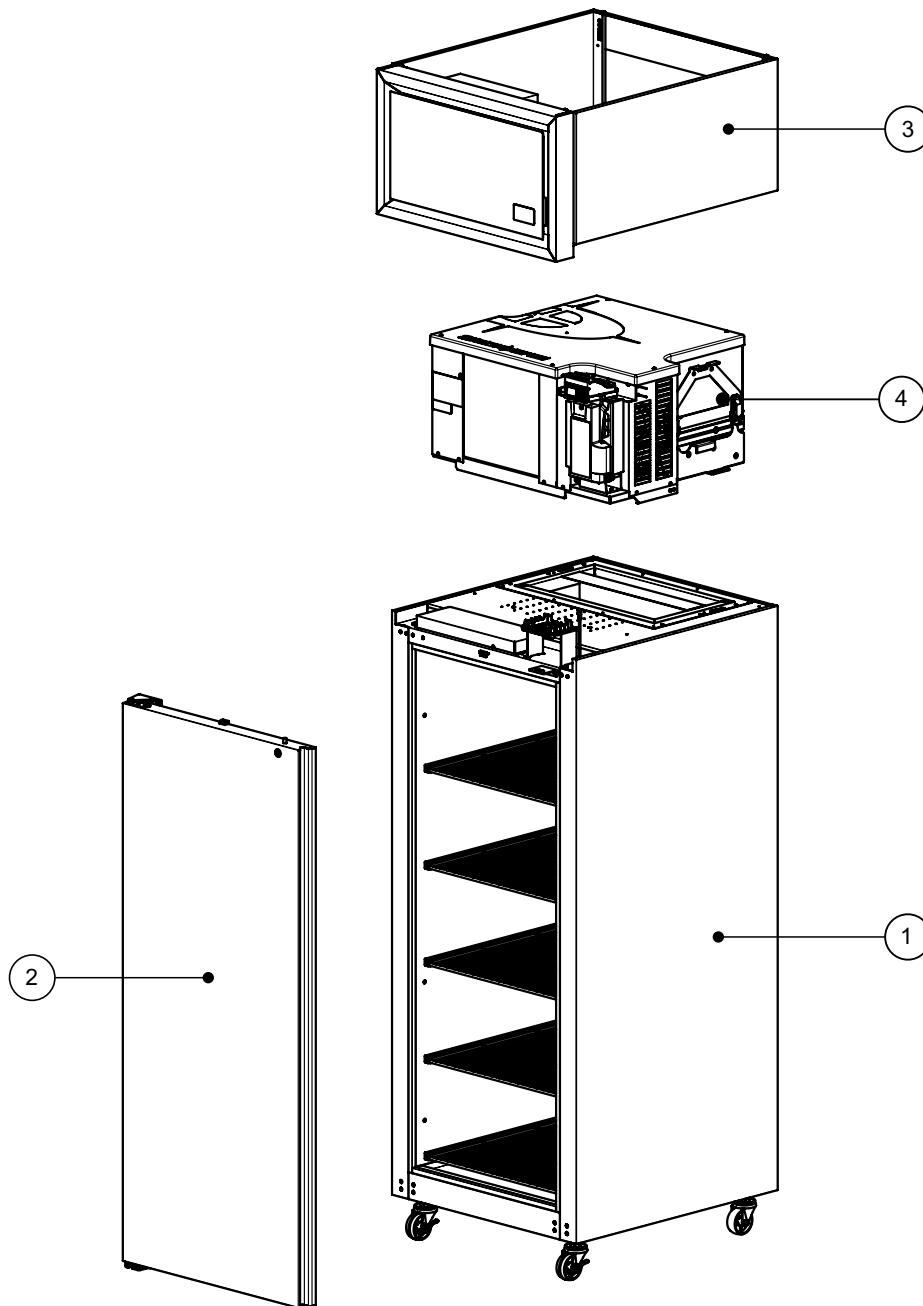

Table 7: Parts – Main assembly: 1-door freezer

No.	Description	Page
1	Cabinet assembly	Page 22
2	Door assembly	Page 26
3	Front panel assembly	Page 27
4	Cartridge assembly	Page 28

Main Assembly – 2-door Freezer

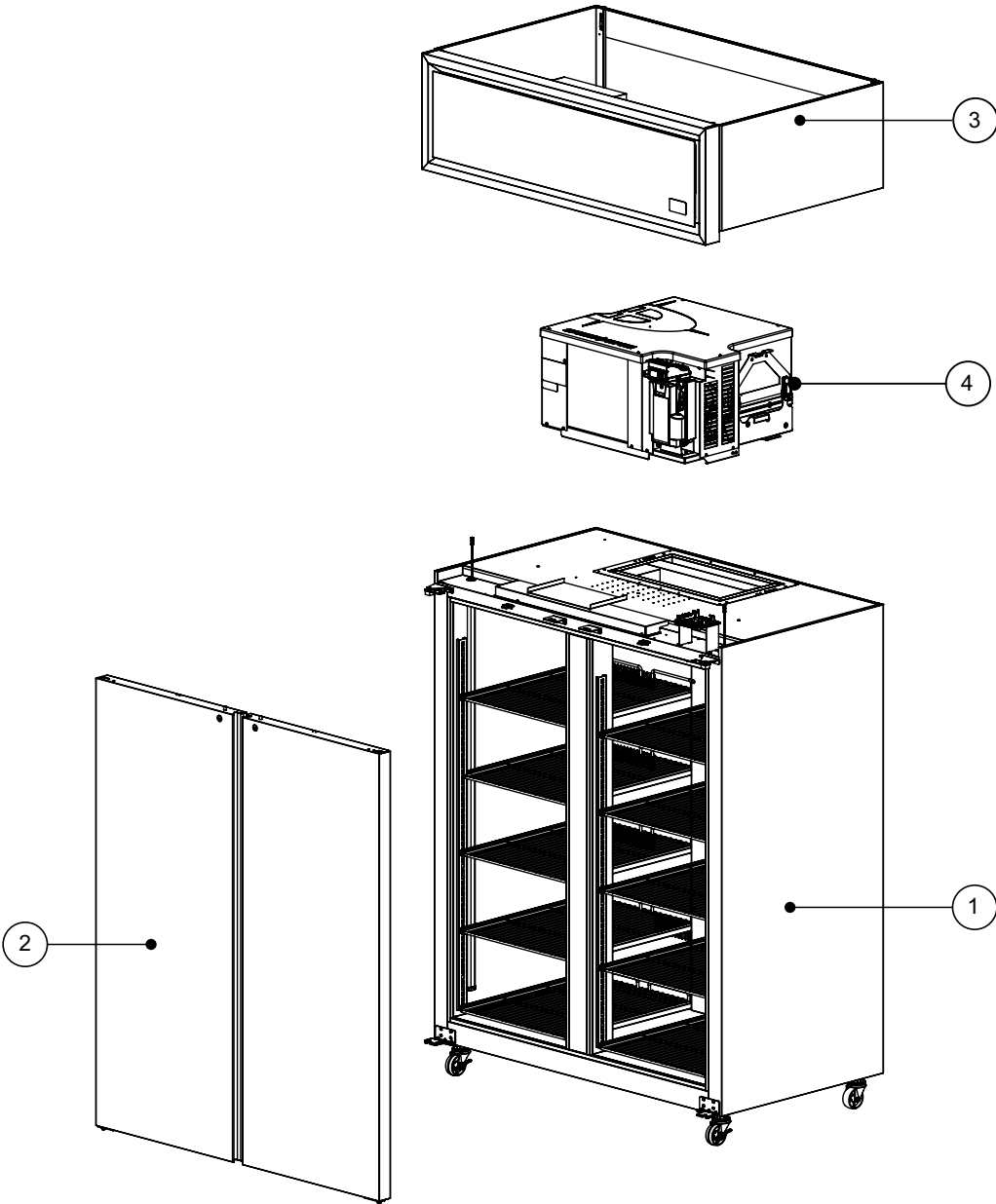

Table 8: Parts – Main assembly: 2-door freezer

No.	Description	Page
1	Cabinet assembly	Page 23
2	Door assembly	Page 26
3	Front panel assembly	Page 27
4	Cartridge assembly	Page 30

Cabinet Assembly – 1-door Cabinet

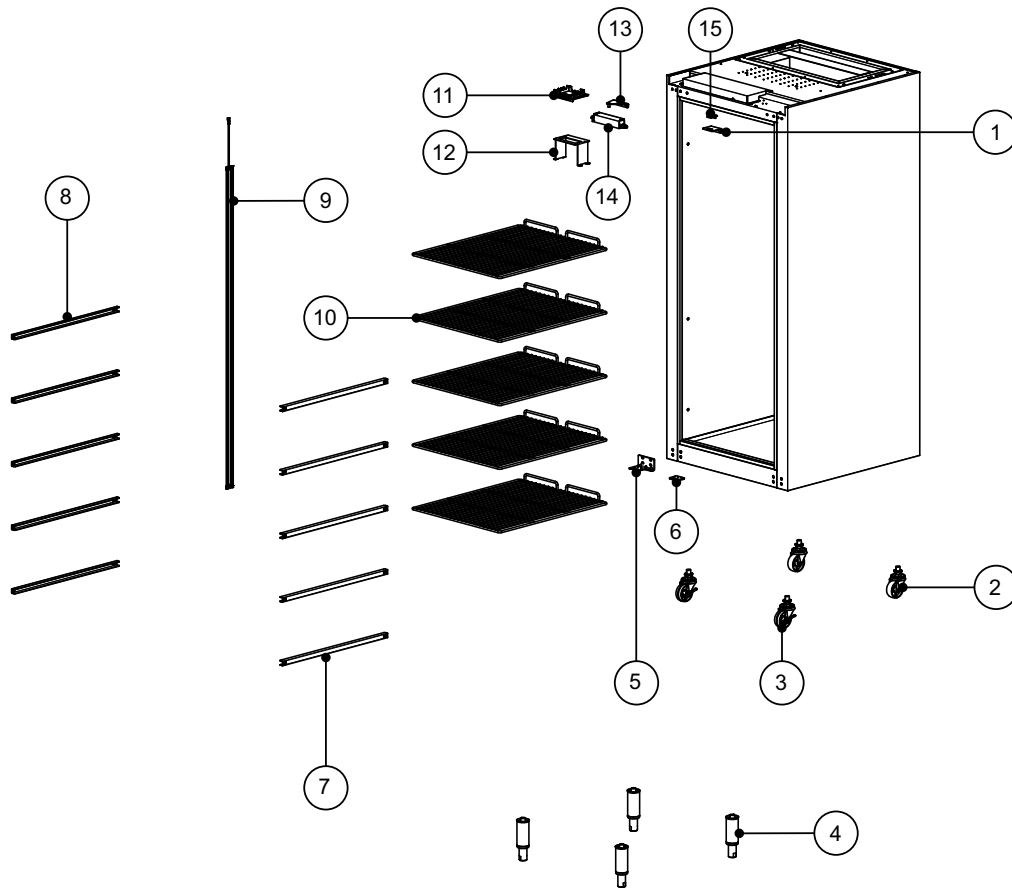

Table 9: Parts – 1-door cabinet assembly

No.	Description	SKOPE Spare Part No.
1	Door locking plate	SKC-2-190-0012-0
2	Adjustable castor (swivel)	SXX6181
3	Adjustable castor (lockable)	SXX6182
4	6" Adjustable Leg (150 mm to 180 mm)	SXX5893
5	Hinge bottom left	SKC-2-190-0008-0
6	Hinge torsion plate	SKC-2-190-0009-0
7	Shelf support strip right	SKC-2-180-0041-0
8	Shelf support strip left	SKC-2-180-0042-0
9	LED light assembly – Clear*	SKC-4-050-0128-0
	LED light assembly – Opaque*	SKC-2-190-0099-0
10	Shelf	SKC-2-190-0013-0
11	Controller clip ABS white	HB0070206333
12	Controller mounting bracket	SKC-2-190-0011-0
13	Hinge top left	SKC-2-190-0007-0
14	LED power supply	ELZ11887
15	Door sensor assembly (includes magnet)	HB0074091496

* Component sub-assembly

Cabinet Assembly – 2-door Cabinet

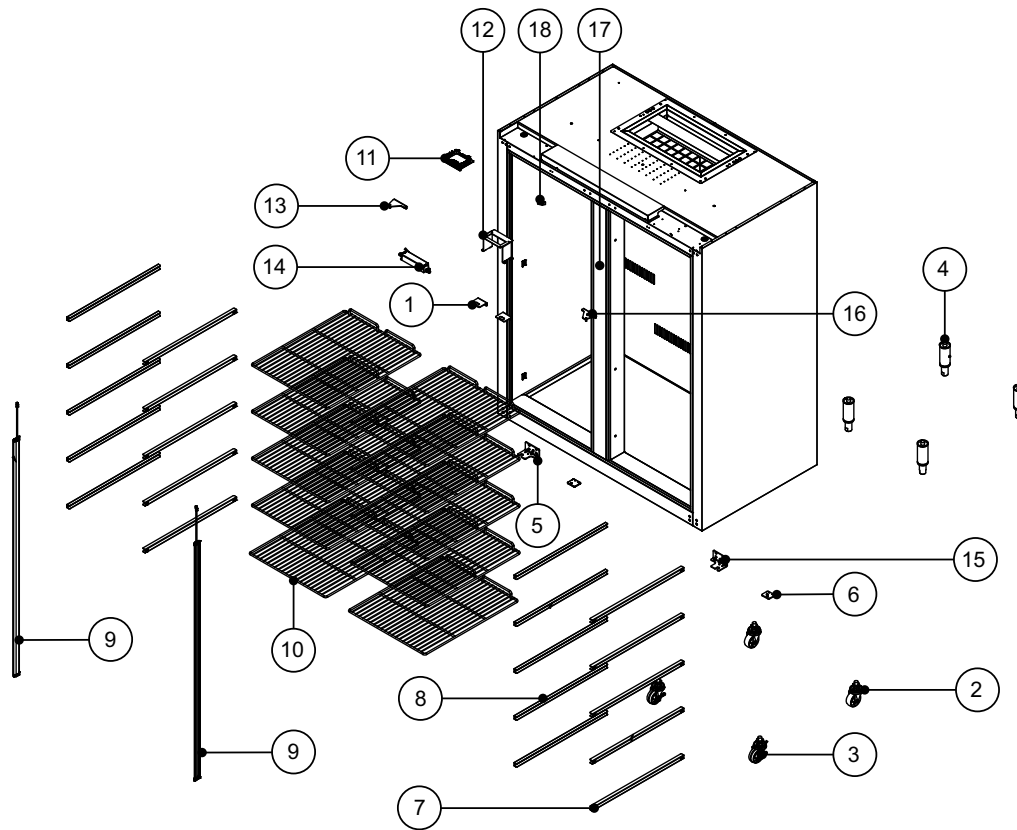

Table 10: Parts – 2-door cabinet assembly

No.	Description	SKOPE Spare Part No.
1	Door locking plate	SKC-2-190-0012-0
2	Adjustable castor (swivel)	SXX6181
3	Adjustable castor (lockable)	SXX6182
4	6" Adjustable Leg (150 mm to 180mm)	SXX5893
5	Hinge bottom left	SKC-2-190-0008-0
6	Hinge torsion plate	SKC-2-190-0009-0
7	Shelf support strip right	SKC-2-180-0041-0
8	Shelf support strip left	SKC-2-180-0042-0
9	LED light assembly – Clear*	SKC-4-050-0128-0
	LED light assembly – Opaque*	SKC-2-190-0099-0
10	Shelf	SKC-2-190-0013-0
11	Controller clip abs white	HB0070206333
12	Controller mounting bracket	SKC-2-190-0011-0
13	Hinge top left	SKC-2-190-0007-0
14	LED Power Supply	ELZ11887
15	Hinge bottom right	SKC-2-190-0023-0
16	Hinge top right	SKC-2-190-0022-0
17	Centre pillar	SKC-0-010-0033-0
18	Door sensor assembly (includes magnet)	HB0074091496

* Component sub-assembly

Solid Door Assembly

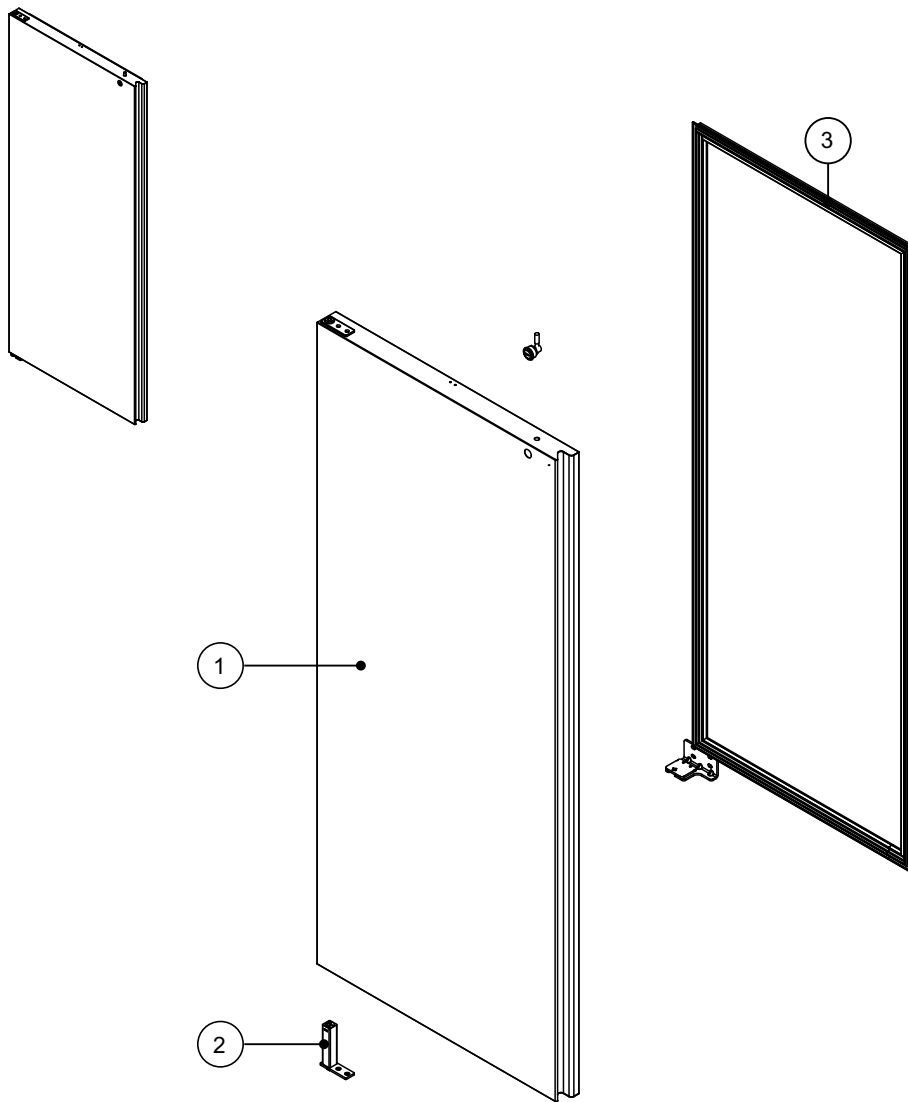

Table 11: Parts – Solid door assembly

No.	Description	SKOPE Spare Part No.	
		1 Door	2 Door
1	Door assembly – left hand	SKC-0-000-1022-0	–
	Door assembly – right hand (reversible option)	SKC-0-000-1031-0	–
	2 Door assembly – left hand	–	SKC-0-000-1014-0
	2 Door assembly – right hand	–	SKC-0-000-1021-0
2	Capstan	SKC-2-170-0410-0	SKC-2-170-0410-0
3	Door gasket	SKC-2-190-0010-0	SKC-2-190-0010-0

Front Panel Assembly

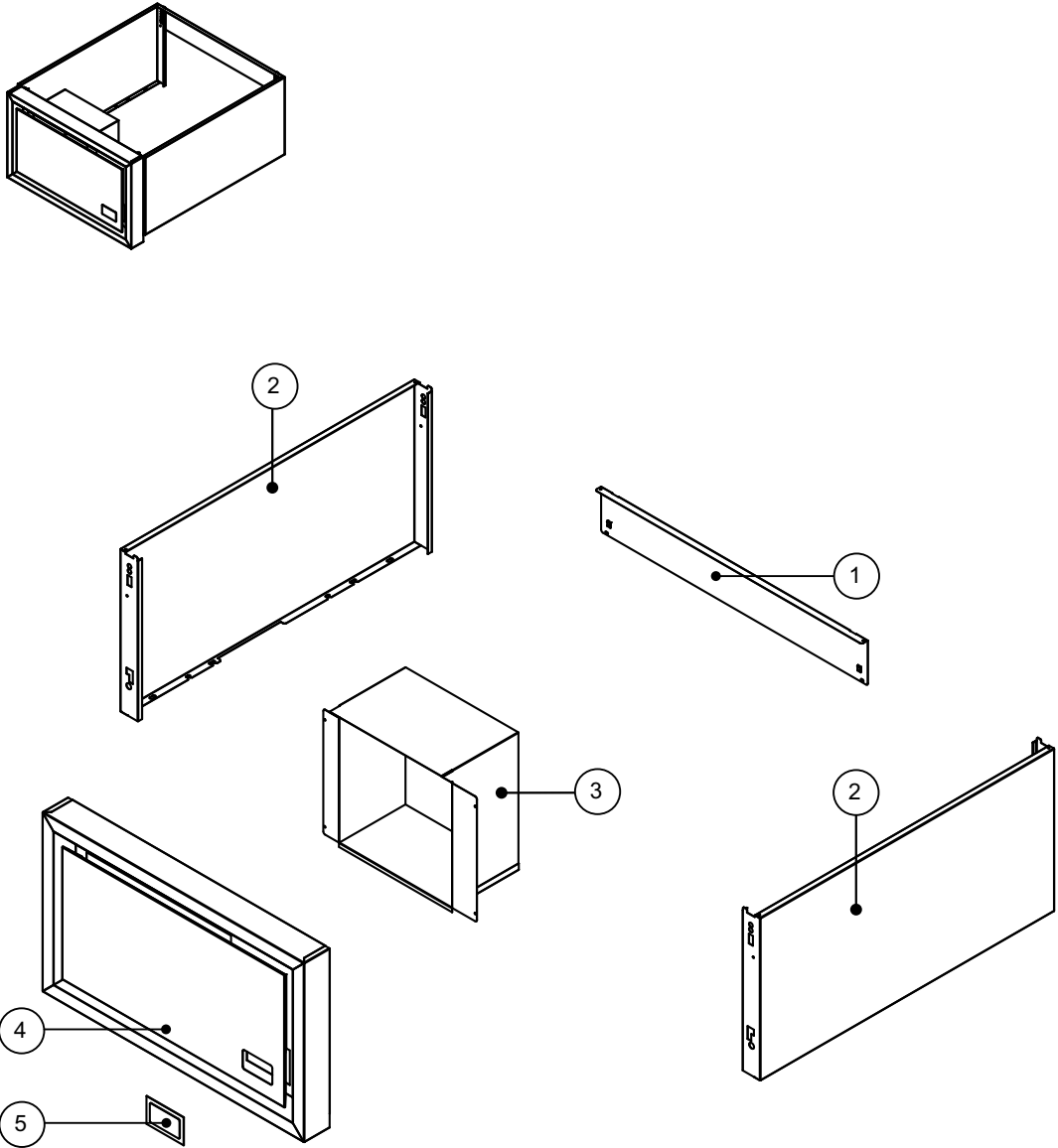

Table 12: Parts – Front panel assembly

No.	Description	SKOPE Spare Part No.	
		1 Door	2 Door
1	Sign back strip	SKC-2-180-0012-0	SKC-2-180-0057-0
2	Sign panel left	SKC-2-180-0234-0	SKC-2-180-0234-0
	Sign panel right	SKC-2-180-0011-0	SKC-2-180-0011-0
3	Baffle	SKC-0-010-0019-0	SKC-0-010-0019-0
4	Front panel assembly (minus baffle)*	SKC-0-010-0036-0	SKC-0-010-0037-0
5	Controller window	PLY124709	PLY124709

* Component sub-assembly

1-door Freezer Cartridge Assembly

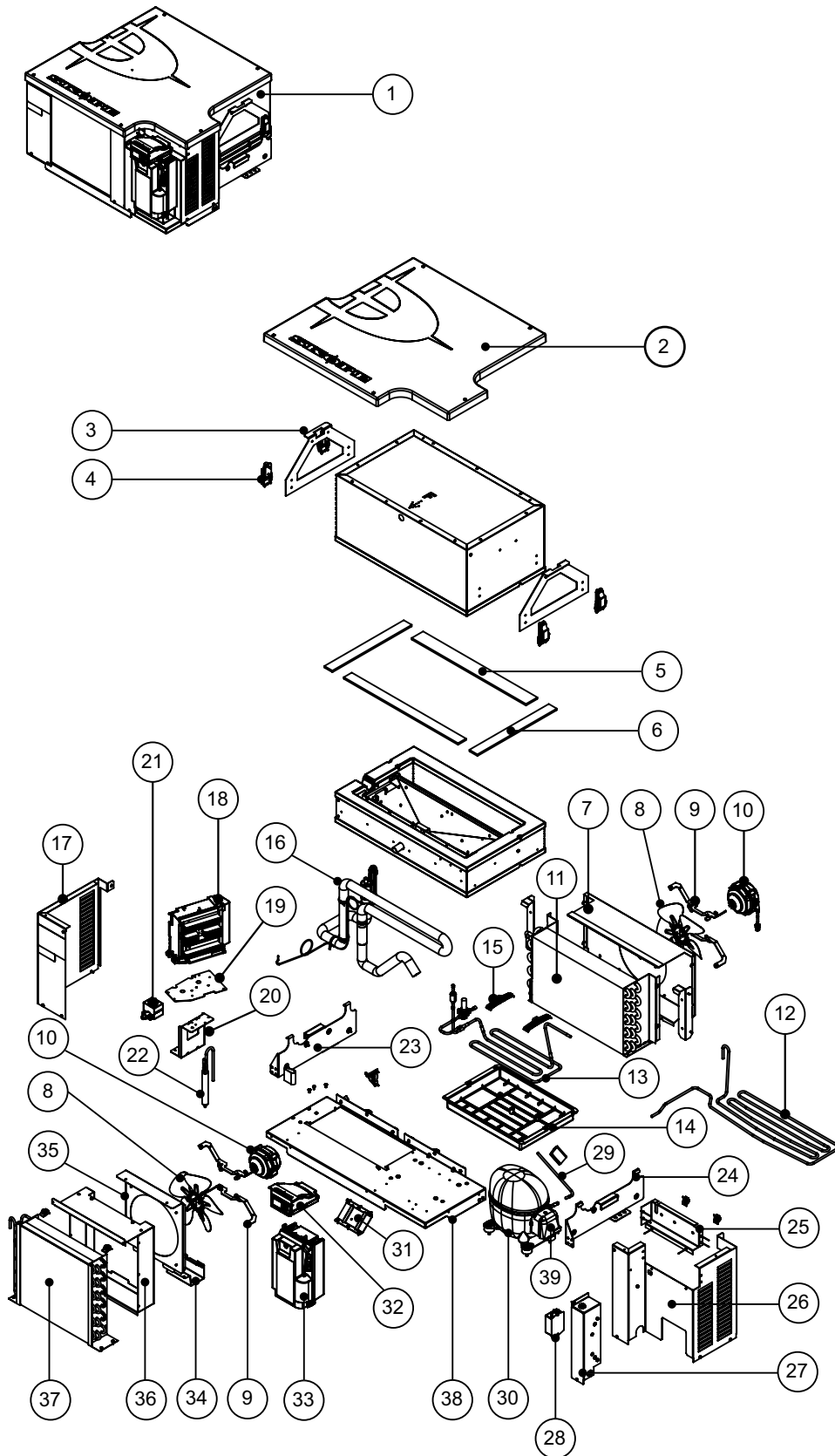

Table 13: Parts – 1-door freezer cartridge assembly

No.	Description	SKOPE Spare Part No.
1	Cartridge assembly	UTHDNI-0043
2	Top cover	HB0070210740
3	Lid handle support	US04N00020
4	Over centre latch	SXX12296
5	Inseal 50 × 6	RUE5120
6	Inseal 35 × 6	RUE12328
7	Evaporator shroud	US02N00021
8	Fan Blade Ø200 28°	HB0074000313
9	Fan motor bracket	HB0070113982
10	ECR2-0361 fan motor ECR2-0361 WDTL	ELM11309
11	Evaporator Coil – 1.0 Circuit	HB0070703152
12	Tube hot gas	HB0070703153
13	Pipework – condensate	HB0070702906
14	Condensate tray	HB0070210452
15	Condensate pipe support	HB0070206128
16	Pipework suction line assembly	HB0070702861
17	cartridge left hand side cover	US04N00014
18	Inverter (compressor power supply)	HB0071800233
19	Inverter top bracket	US05N00016
20	Inverter bracket	HB0070114715
21	Solenoid valve assembly*	HB0074000545A
22	20GN spun drier	HB0070700780
23	Bracket left hand tub side	HB0070114713
24	Bracket right hand tub side	HB0070114712
25	Cover cartridge front top	US04N00015
26	Cartridge right hand side cover	US04N00013
27	Cover EMI filter	HB0070114716
28	Schaffner EMI filter FN2030Z-10-06	ELZ10136
29	Process tube	HB0070703196
30	Embraco compressor – VNEU217U	HB0074001133
31	Bracket cartridge brace	HB0070114717
32	“Electronic Controller Assembly” on page 32*	UA0300021-616
33	“Electrics Junction Box Assembly” on page 33	–
34	Junction box support bracket	HB0070114714
35	Motor mount	US02N00019
36	Condenser fan shroud	US02N00018
37	Condenser coil	HB0070702907
38	Cartridge base	HB0070114711A
39	Compressor overload protector	SXX12497

* Component sub-assembly

2-door Freezer Cartridge Assembly

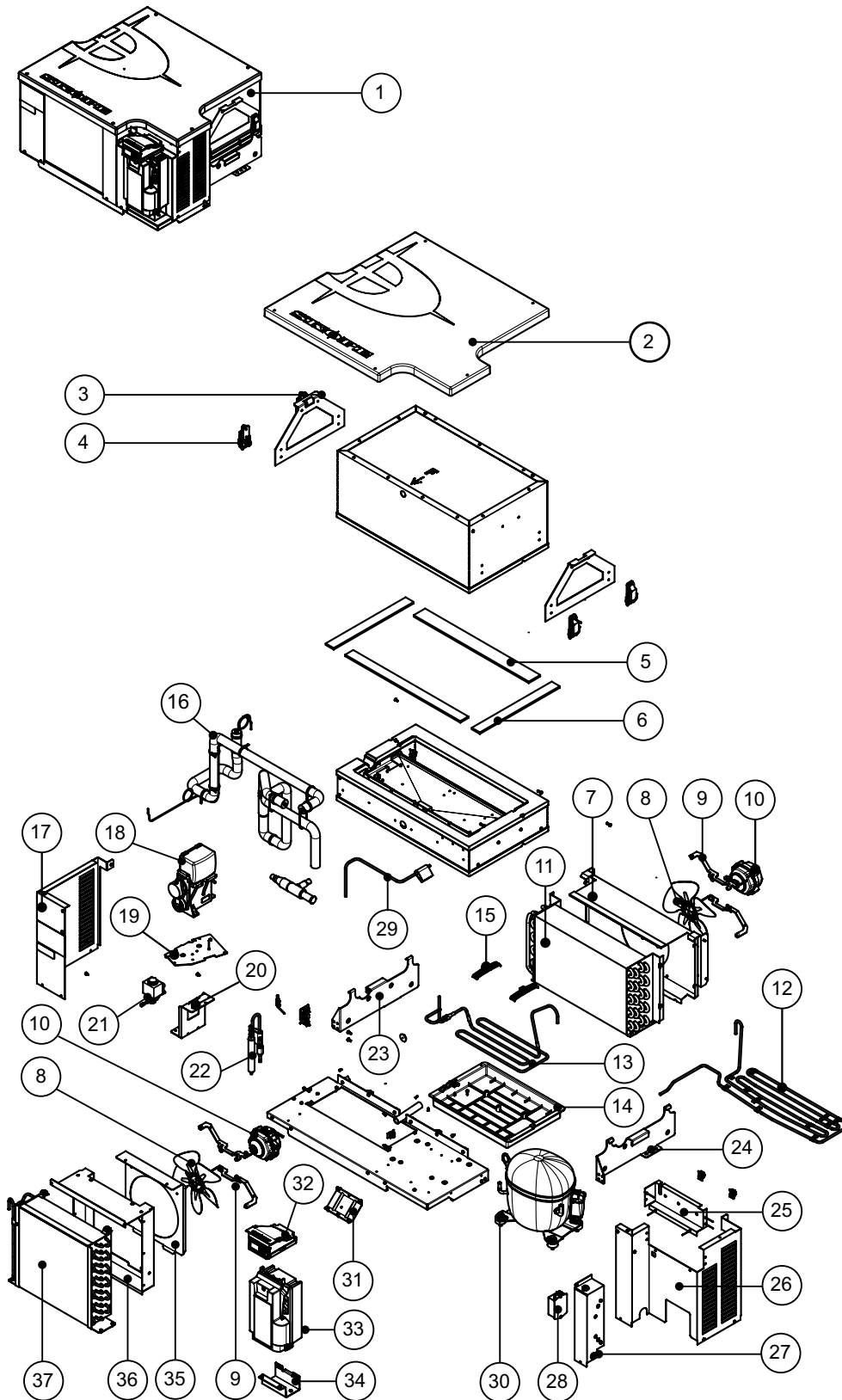

Table 14: Parts – 2-door freezer cartridge assembly

No.	Description	SKOPE Spare Part No.
1	Refrigeration cartridge assembly*	UTHDNI-0051
2	Top cover	UP02N00005
3	Lid handle support	US04N00020
4	Over centre latch	SXX12296
5	Inseal 50 × 6	RUE5120
6	Inseal 35 × 6	RUE12328
7	Evaporator shroud	US02N00022
8	Fan blade Ø200 28°	HB0074000313
9	Fan motor bracket	HB0070113982
10	ECR2-0361 fan motor ECR2-0361 WDTL	ELM11309
11	Evaporator coil – 1.0 circuit	CLS12425
12	Tube hot gas	UT06N00008
13	Pipework – condensate	UA0100023
14	Condensate tray	UP10N00006
15	Condensate pipe support	UP10N00001
16	Pipework suction line assembly*	UA0400023
17	Cartridge left hand side cover	US04N00014
18	Inverter (compressor power supply)	–
19	Inverter top bracket	–
20	Inverter bracket	–
21	Solenoid valve assembly*	HB0074000545A
22	20GN spun drier	HB0070700780
23	Bracket left hand tub side	HB0070114713/12
24	Bracket right hand tub side	HB0070114713/12
25	Cover cartridge front top	US04N00015
26	Cartridge right hand side cover	US04N00013
27	Cover EMI filter	US07N00021
28	Schaffner EMI filter FN2030Z-10-06	ELZ10136
29	Process tube	UT04N00006
30	Embraco compressor – NTX2213U	CPR12461
31	Bracket cartridge brace	US04N00019
32	“Electronic Controller Assembly” on page 32	UA0300021-630
33	“Electrics Junction Box Assembly” on page 33	–
34	Junction box support bracket	US04N00016
35	Motor mount	US02N00019
36	Condenser fan shroud	US02N00020
37	Condenser coil	CLS12446

* Component sub-assembly

Electronic Controller Assembly

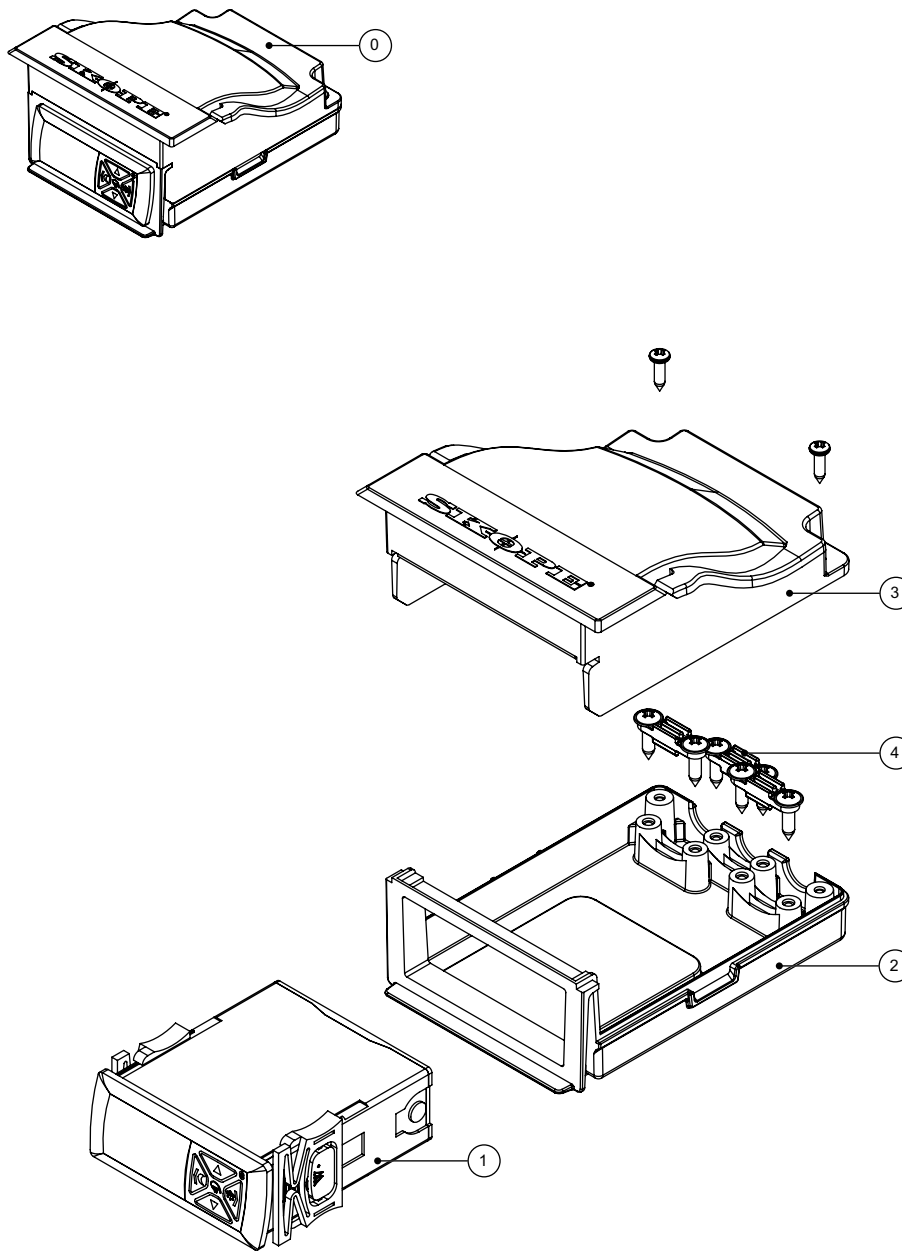

Table 15: Parts – Electronic controller

No.	Description	SKOPE Spare Part No.
0	Electronic controller assembly*	HB0070833377
1	Wellington drive controller	ELZ11749-1629
2	Controller housing base	HB0070206125
3	Controller housing cover	HB0070206126
4	Cable clamp	HB0070206127

* Component sub-assembly

Electrics Junction Box Assembly

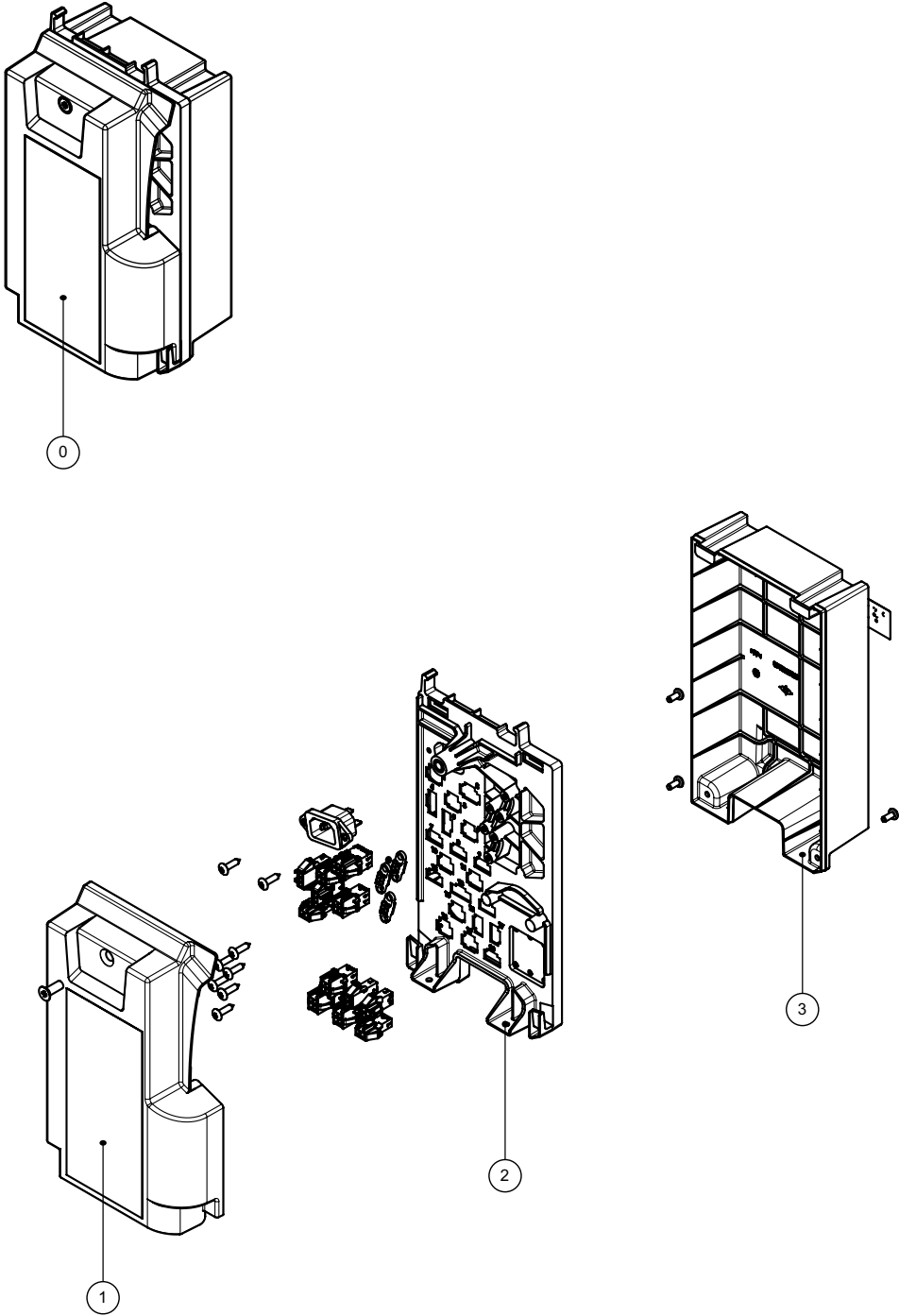

Table 16: Parts – Electrics box assembly

No.	Description	SKOPE Spare Part No.
0	Electrics junction box assembly*	
1	Electrical front panel	HB0070207012A
2	Electrical enclosure panel	HB0070207014
3	Electrical rear panel	HB0070207013A

* Component sub-assembly

6 Installation

Installation Guidelines

When installing this cabinet, ensure the installation guidelines below are considered and met.

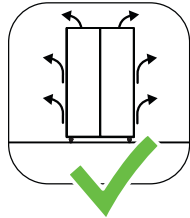

Ventilation

Ensure all ventilation requirements below are met.

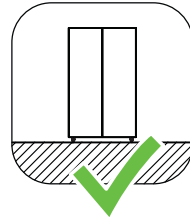

Surface

The installation surface must be capable of supporting the loaded cabinet.

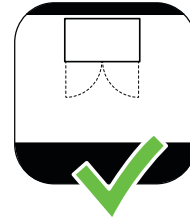

Door Opening

Allow adequate space for the door/s to open and close properly.

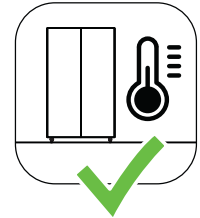

Climate Class

The cabinet must be installed in an environment within its climate class. The climate class is stated on the cabinet rating label inside the cabinet.

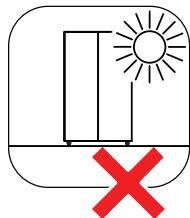

Sunlight

Do not install the cabinet in direct sunlight.

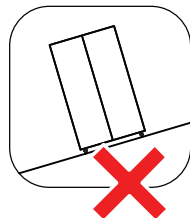

Uneven Surface

Do not install the cabinet on an uneven surface.

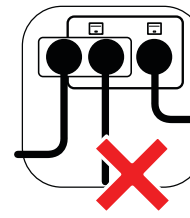

Power Supply

Do not overload the power supply.

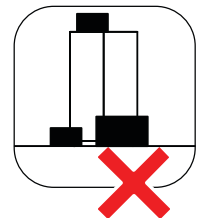

Blocking Ventilation

Do not store boxes or items in front or on top of the cabinet.

Ventilation Requirements

See the diagram below for ventilation requirements.

- When positioning the cabinet, ensure there is at least a 300 mm space above the top panel. Adequate ventilation around the refrigeration cartridge is essential for efficient operation.
- The air surrounding the refrigeration cartridge must not exceed 40°C.
- Keep the ventilation slots at the top of the cabinet clear at all times and **never** store cardboard cartons or other objects on top of the cabinet.

- In certain climatic conditions, condensation may form on the back of the cabinet. If this is observed, ensure air circulation between cabinet and wall by adhering two of the enclosed self-adhesive blocks to the cabinet back as shown.

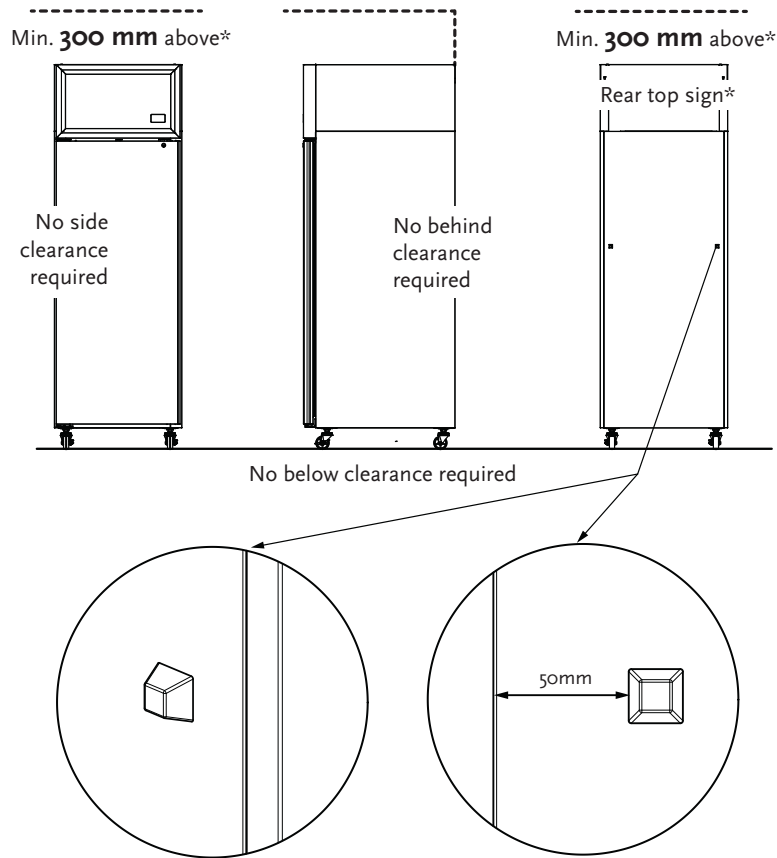

Adhesive Blocks

If required use two adhesive blocks on the rear of the cabinet. Position the blocks on the left and right hand sides of the cabinet, approximately in the centre and 50 mm from the cabinet edge.

Shelves

The cabinet is fitted with five wire shelves per door, which may be positioned at different heights to suit various products

Shelf Support Strips Each wire shelf is held in place by two shelf support strips, which engage in the shelf support strips and slide up and down to the desired shelf position.

The support strips are numbered for easy location of shelf clips. View the numbers in the bottom left hand corner of the shelf clip.

Procedure 4: To fit a shelf support strip

The shelf support strips hook into vertical supports on the left and right sides of the cabinet.

1. Engage the rear hook on the shelf support strip first, then the front hook.

-
2. Check that the shelf support strip is secure.
-



Procedure 5: To remove a shelf support strip

1. Pull the front of shelf support strip **up** and **away** from the vertical support. This will free up the front section of the support strip.

2. Pull the rear shelf support strip **forward** and **away** from the cabinet.
-

Procedure 6: To adjust a shelf support strip

The cabinet vertical supports are spaced at different heights to allow for various shelf positions.

1. Remove the shelf support strip as above.

-
2. Hook the shelf support strips into the notch features on the cabinet vertical supports.
-



Repositioning Shelves

Procedure 7: To reposition a standard shelf

1. Unload the shelf and remove it from the cabinet.
 2. Move each shelf to the new position in the shelf support strips.
 3. Replace the shelf back in the cabinet.
-

7 Operation

Loading Product

Let the cabinet run for 30 minutes before loading it with product for the first time. When loading the cabinet:

- Do not exceed a maximum load of 46kg per shelf (standard shelves).
- Remove some product if the shelves are flexing and do not let anything overhang the shelves because this might stop the doors from shutting or cause potential cabinet damage.

Light Switch

The lights can be switched on and off by pressing and holding the **AUX** button on the electronic controller display (see page 9).

Refrigeration Cartridge Type Overview

Hot Gas Defrost This cabinet has hot gas defrost. It uses the superheated vapour from the compressor discharge as the heat source. This travels in copper tubes, bypassing the condenser and expansion device (the capillary). From the solenoid valve (located under the compressor inverter), the copper tubes are attached to the underside of an aluminium tray which heats the evaporator drain tray. From here the hot gas enters and defrosts the evaporator coil.

Once the evaporator probe (attached to the outlet of the evaporator) reaches 15°C, the termination temperature, there are 4 minutes of passive drip time (no evaporator fan), followed by 1 minute of active drip time (the evaporator fan is operating) to cool the inverter. The condenser fan motor operates continuously during defrost.

The typical hot gas defrost time is 2 to 8 minutes (depending on the amount of ice) every 3 hours. The maximum defrost time is limited to 15 minutes. If the defrost runs to 15 minutes, there may be a refrigeration system fault because the evaporator probe has not reached the 15°C termination temperature.

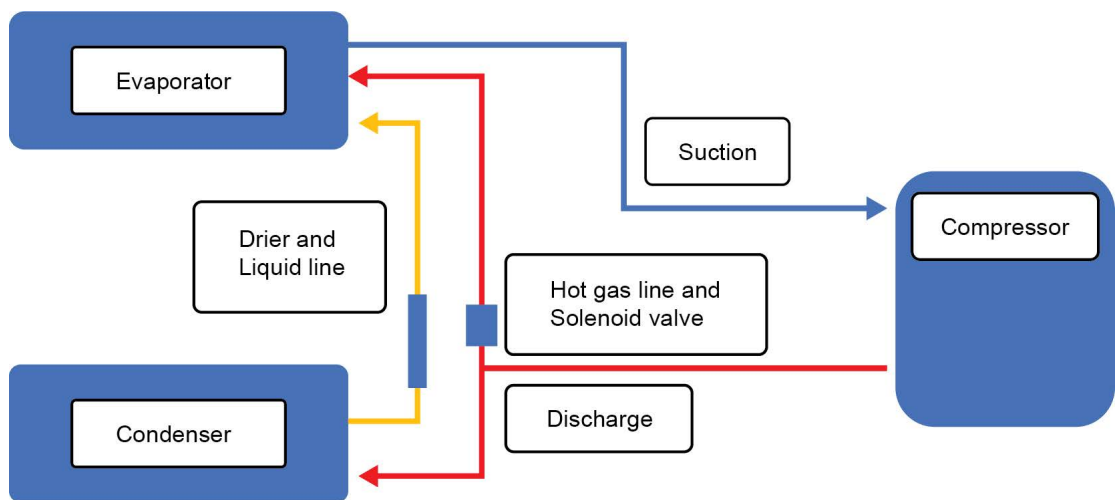

Both refrigeration cartridge types share same cartridge structure platform, with a unique capillary expansion device and hot gas defrost.

UTHDNI-0043

The cartridge for the single door cabinet uses an inverter-driven 17cc variable speed compressor, with 3 row heat exchange coils, and no crankcase pressure regulator.

UTHDNI-0051

The cartridge for the two-door cabinet uses a traditional fixed speed 33cc compressor with 4 row heat exchange coils, and a crankcase pressure regulator.

Refrigeration System Diagnostics – Function Test 1-Door Freezer

Cartridge UTHDNI-0043 – one-door freezer refrigeration cartridge

Because of the ultra-low R290 charge and variable speed compressor, SKOPE does not recommend connecting into the sealed system with line-piercing valves to measure the operating pressure.

Use this method to determine if there is a sealed system fault before breaking into the sealed system.

Procedure 8: To determine if there is a sealed system fault

Before you start

The cartridge may be fitted on the cabinet or sitting on a workbench.

1. Soak the evaporator coil and refrigeration system to room ambient temperature (20°C).
2. Remove the cartridge's top cover.
3. Remove the evaporator box top:
 - Undo the four latches.
 - Lift upwards and off.

4. Sit the cartridge's top cover between the front of the evaporator coil and the rear condenser fan to stop the condenser air blowing onto the evaporator coil.

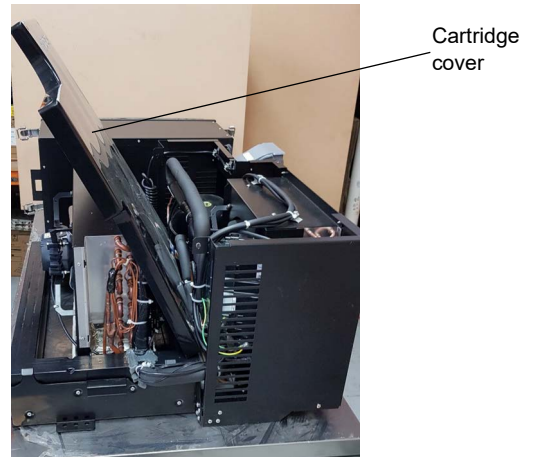

5. If the cartridge is not fully plugged into the cabinet, plug a probe into the door plug within the electrical box, as a bypass.

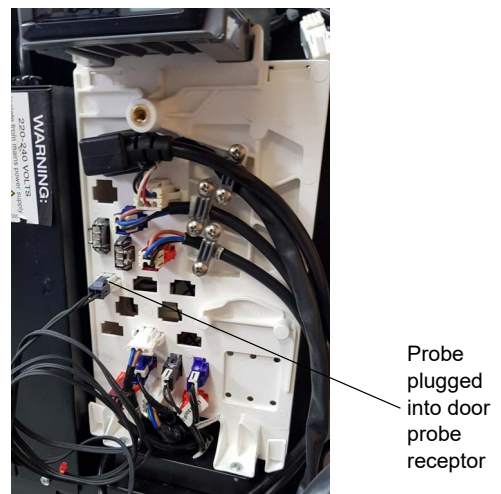

6. Perform a run test, looking for the typical characteristics of a correctly operating refrigeration system in the table below.

Sealed system run test table

This table indicates the typical characteristics for a correctly operating refrigeration system

NOTE
The evaporator fan start/run function as below is the primary outcome indicating correct operation.

If a fault may be present with the sealed system, refrigerant charge, compressor, inverter, defrost solenoid valve, or electrical system. For controller specific issues, fault codes, etc, See “Electronic Controller” on page 8

Time – approx (after plug in)	First plug in	20 secs	1 min	2 mins	5 mins	7 mins typically – BEFORE evap fan starts	8 mins typically – evap fan STARTS	After 10 minutes PRESS manual defrost	17.5 mins	
Control display	Display on, start code, then ambient temperature	Ambient temperature	Temperature reduces				Temperature increases when evaporator fan is on		Manual defrost duration approx 2.5mins, then 5mins DRIP time	Temperature increases
Compressor	OFF	ON	ON	ON	ON	ON compressor speeds up (audible)	ON – hot to touch	OFF		
Evaporator coil	Dry	Dry	Ice on evaporator capillary and evaporator Y inlet tube up to coil		ice on all evap coil return bends			Evaporator coil warm		
Condenser fan	Twitch	ON	ON	ON	ON	ON	ON	OFF	OFF	
Evaporator fan	Twitch	OFF	OFF	OFF	OFF	OFF	ON (approx 30secs), then off for up to 3mins	OFF	OFF, except ON for final 1 minute of defrost drip time	
Inverter LED	One green flash every 30 seconds									
Current amps (excluding cabinet)	0.3	4.5	1.6	1.7	1.6	3.0	4.1	5.9 peak	0.2	
Watts (excluding cabinet)	14	1020	336	367	348	664	926	1300 peak	6	
Field App Evaporator coil OUTLET Temp	Ambient 20°C		24°C	23°C	4°C	Trigger for evap fan ON @ -5°C.... Then evap fan OFF <-4°C		Increases during defrost, at 5°C defrost heating ends and compressor stops (approx 2.5 minutes), then 5 minutes drip time		
Field App Return Air Temp	Ambient 20°C		23°C	20°C	6°C	Varies with fan on/off/defrost				
Field App Condenser Temp	Ambient 20°C		26°C	'27C	'28C	Varies, continues up to 32C during defrost				

Compressor and Inverter Information

The following diagnostic information is for the Embraco variable speed compressor.

Note in cases where a compressor is confirmed faulty then the inverter should also be replaced. However if an inverter is faulty then a working compressor should not be replaced

Inverter LED Indication

The LED diagnostics function helps service technicians to diagnose possible component faults by blinking an LED inside the inverter box in different patterns. This indicates if there is a problem with the compressor

LED Status	Period	Colour	Description
1 Flash	30 seconds	Green	Normal operation
2 Flash	5 seconds	Green	Communication problem
3 Flash	5 seconds	Red	Inverter problem
4 Flash	5 seconds	Amber	Compressor problem
No Flash	–		No input power/ Damaged inverter

Trouble-shooting

Compressor does not start	
Problem	Action
Compressor disconnected from the inverter	Verify compressor cable connection and compressor protector plugs
No control signal input or bad connection from controller	Verify control input cable connection and measure the signal from the controller
Open compressor winding	Measure winding for open circuit between all pairs of pins on the hermetic terminal. If any winding is open, compressor is faulty
Compressor with locked rotor (due to mechanical damage)	Replace compressor and inverter
Low input voltage supplied to the inverter	Measure AC voltage to confirm
Inverter / compressor fault trip	Wait for cooling and reset time of inverter (1 - 10 minutes), Compressor (protector 60 minutes)
Compressor change of noise and or speed	Normal function, varies to load according to inverter algorithm

Compressor The compressor is located at the front of the refrigeration cartridge, beside the condenser. If the compressor is causing excessive noise, check the mountings to ensure there is no damage to the rubber or the washers, nuts and screws.

NOTE

Variable speed compressor may change speed rapidly under normal function, resulting in a change of pitch.

The compressor over current protector is located directly on compressor terminals (under compressor electrics cover). All other electrical power is supplied directly from the compressor inverter (located on opposite side of cartridge).

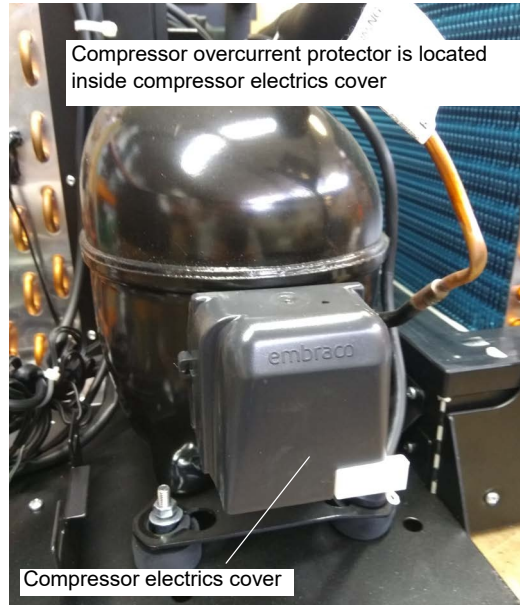

IMPORTANT
To eliminate possible vibration noise, ensure condensate pipes are clamped onto base of condensate tray. It is important the compressor discharge pipe is tightly clamped at entry to this tray or high frequency vibration may occur.

Compressor Inverter The inverter is non-serviceable component. For diagnostics see “Inverter LED Indication” on page 41.

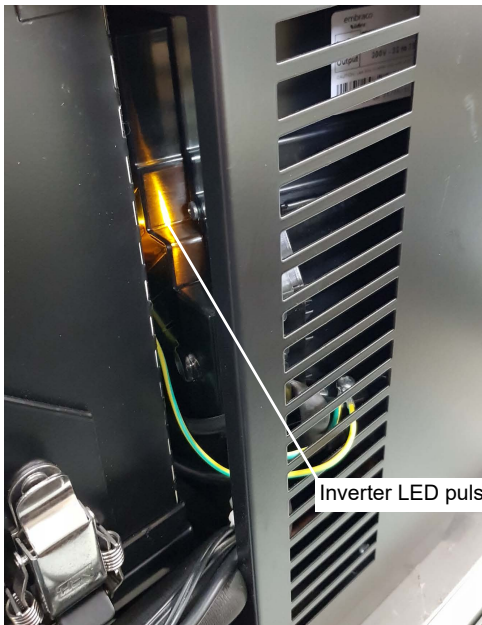

Refrigeration System Diagnostics – Function Test 2-Door Freezer

Cartridge UTHDNI-0051 – two-door freezer refrigeration cartridge

Because of the ultra-low R290 charge and variable speed compressor, SKOPE does not recommend connecting into the sealed system with line-piercing valves to measure the operating pressure.

Use this method to determine if there is a sealed system fault before breaking into the sealed system.

Procedure 9: To determine if there is a sealed system fault

Before you start

The cartridge may be fitted on the cabinet or sitting on a workbench.

1. Soak the evaporator coil and refrigeration system to room ambient temperature (20°C).
2. Remove the cartridge's top cover.
3. Remove the evaporator box top:
 - Undo the four latches.
 - Lift upwards and off.

4. Sit the cartridge's top cover between the front of the evaporator coil and the rear condenser fan to stop the condenser air blowing onto the evaporator coil.

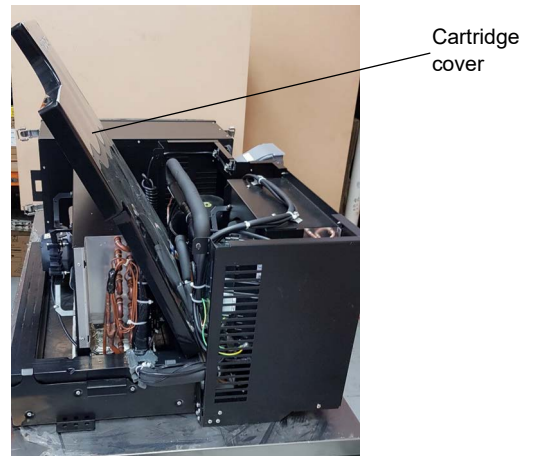

5. If the cartridge is not fully plugged into the cabinet, plug a probe into the door plug within the electrical box, as a bypass.

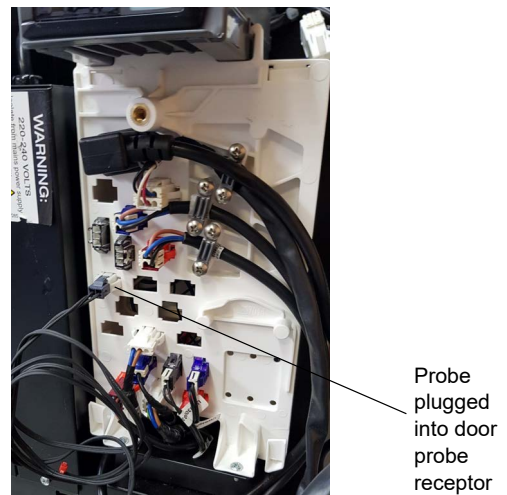

6. Perform a run test, looking for the typical characteristics of a correctly operating refrigeration system in the table below.

Sealed system run test table

This table indicates the typical characteristics for a correctly operating refrigeration system

NOTE
The evaporator fan start/run function as below is the primary outcome indicating correct operation.

If a fault may be present with the sealed system, refrigerant charge, compressor, inverter, defrost solenoid valve, or electrical system. For controller specific issues, fault codes, etc, See “Electronic Controller” on page 8

Time – approx (after plug in)	First plug in	4 mins	5.5 mins typically – before evap fan STARTS	6 mins typically – before evap fan STARTS	After 7 minutes PRESS manual defrost	12 mins – end of drip time
Compressor	Off, then start at 20 secs	ON	ON compressor speed up (audible)	ON – hot to touch	Manual defrost duration approx. 2 mins, then 5 min DRIP time	OFF
Evaporator coil	Dry	ice on all evaporator coil return bends				Evaporator coil warm
Accumulator	Dry	Cold to touch – No ice			n.a	
Condenser fan	Twitch	ON	ON	ON	ON	OFF
Evaporator fan	Twitch	OFF	OFF	ON (approx 30 secs), then off for up to 3 mins	OFF	OFF for 4 minutes of drip time, ON for final 1 minute of defrost drip time

Compressor

The compressor is located at the front of the refrigeration cartridge, beside the condenser. If the compressor is causing excessive noise, check the mountings to ensure there is no damage to the rubber or the washers, nuts and screws.

The compressor over-current protector is located within compressor body.

Compressor power is supplied directly from the compressor electrical supply box (start relay, start and run capacitor), located on left hand side of unit (opposite the compressor).

Compressor Electrical Supply Box The image below shows the covers removed from the refrigeration cartridge. It indicates where the compressor electrical supply box is located within the cartridge.

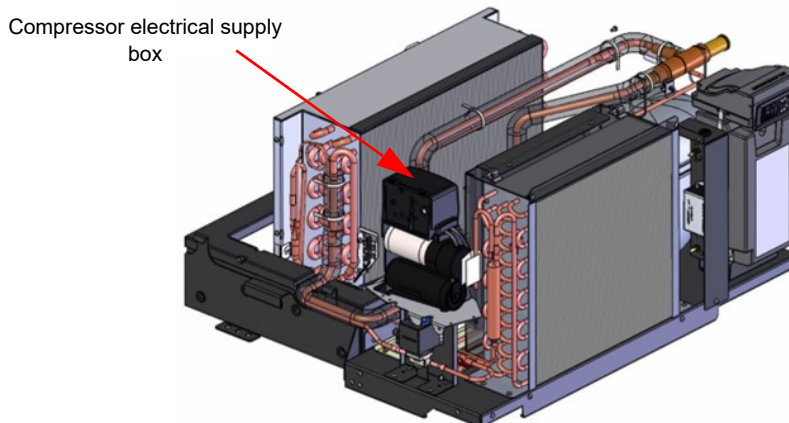

- Compressor Connections**
- Black wire (common) top FASTON
 - White wire (start) left FASTON
 - Red wire (run) right FASTON

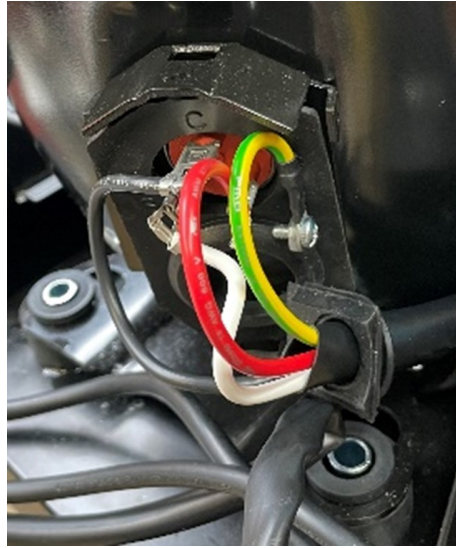

Crankcase Pressure Regulator The crankcase pressure regulator is fitted to protect the compressor from overloading during the hot gas defrost. The valve is preset to 345 kPag and should not be adjusted (higher pressure will damage compressor, and lower pressure will prevent effective defrosting).

Crankcase pressure regulator
(cartridge covers removed)

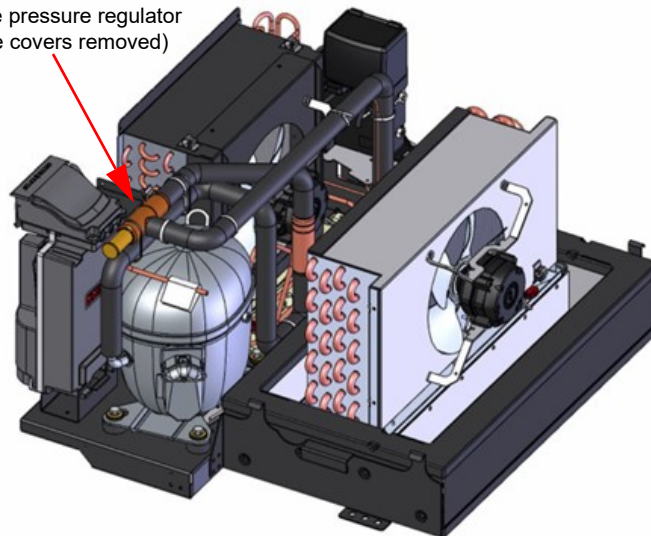

8 Replacement Procedures

Refrigeration System

Before Servicing Overview

Ensure you have read and understood this manual before starting any servicing.

Important

- SKOPE hydrocarbon refrigeration systems must only be serviced by appropriately skilled and qualified refrigeration mechanics.
- Servicing a sealed refrigeration system must occur at a hydrocarbon workshop or service area with dedicated hydrocarbon equipment and personal protective equipment (PPE).
- All local hydrocarbon storage and handling regulations and procedures must be followed at all times.

Ensure all electronic controller alarms diagnostics and refrigeration system diagnostics are performed to confirm a refrigeration system fault is present.

Check all components including the electronic controller and electrical systems.

Ensure your work area is well ventilated.

IMPORTANT

Use only dedicated hydrocarbon SKOPE OEM spare parts.

DO NOT use alternative parts.

For safety compliance, use only SKOPE-supplied components specified for the appliance.



Safety hazards

The main hydrocarbon safety hazards are:

- Flammability
- Venting of hydrocarbon and compressor oil
- Asphyxiation

Refrigerant identification

Correctly identifying the refrigerant is critical to maintain safety and the correct functioning of the cabinet.

- The cabinet rating label (located in the upper inside of the cabinet) states the refrigerant type.
- Warning labels are fitted to hydrocarbon refrigeration coolers to indicate the use of hydrocarbon refrigerant.

Personal protective equipment (PPE)

Correctly wear or use all PPE required by local regulations and procedures during servicing.

Service equipment

Only use dedicated hydrocarbon service equipment which is hydrocarbon-compliant. Electrical equipment that could be exposed to the refrigerant must be intrinsically safe.

In addition to standard tools for accessing and removing parts, specialist tools are required for completing the refrigeration system service tasks in this manual:

- Intrinsically safe refrigeration vacuum pump, rated by the manufacturer as suitable for use with hydrocarbon refrigerant

- Dedicated hydrocarbon gauge set
- Flammable gas detector to warn if flammable refrigerant is present
- Charging scales, rated by the manufacturer as suitable for use with hydrocarbon refrigerant, accurate to 1.0 gm

Leak detector

A leak detector is used to track and locate the source of hydrocarbon gas leaks. It is:

- recommended for servicing hydrocarbon units on-site.
- required for servicing hydrocarbon units off-site.

Service vehicle

- Must be suitable for transporting flammable gas.
- Vehicle cargo area:
 - Must be well ventilated to outside the vehicle only.
 - Must have no ignition sources, nor any areas where the gas may pool.
- Must be able to transport swap units.
- Should carry minimum SKOPE hydrocarbon service parts.

On-site Work The service technician must have required knowledge, skills, qualifications, and tools before beginning any on-site work on the refrigeration sealed system.

Minimum knowledge and skills

- Qualifications and certifications required by local/state regulatory bodies to service hydrocarbon refrigeration systems
- Safe working practices, including a safe working environment at all times

Minimum tools and equipment

- Safety signage and/or barrier – suitable to create a safe work zone 1.5 m around the cabinet
- Hydrocarbon gas detector
- Dedicated hydrocarbon gauge set
- Bullet valves/line piercing valves suitable for a 6 mm tube

Off-site Work Hydrocarbon workshop

The following tools and equipment are required in the hydrocarbon workshop:

- Dedicated area for hazardous work – suitable for servicing and releasing flammable hydrocarbon refrigerant
- Hydrocarbon leak detector
- Refrigeration gauge set – suitable for flammable hydrocarbon refrigerant
- Dry nitrogen – suitable for purging and high pressure testing
- Intrinsically safe refrigeration vacuum pump, rated by the manufacturer as suitable for use with hydrocarbon refrigerant
- Charging scales, rated by the manufacturer as suitable for use with hydrocarbon refrigerant, accurate to 1.0 gm
- Hydrocarbon refrigerant supply cylinder

Refrigeration Cartridge Assembly

The refrigeration cartridge is a top-mounted, electronically controlled removable cartridge.

For safety and compliance, only SKOPE supplied parts specifically for this appliance may be used for repairs. Other parts may appear to be suitable, but may not be approved or safe for use in an appliance with hydrocarbon refrigerant.

The cartridge must only be used on a SKOPE hydrocarbon-compliant cabinet. Refer to the cabinet rating label to determine if the cabinet is suitable for use with a hydrocarbon cartridge.

The rating label MUST state refrigerant as R290. If the label states a different refrigerant, or does NOT state a refrigerant, it is NOT suitable for a hydrocarbon cartridge.

WARNING
The hydrocarbon cartridge must only be used on an hydrocarbon-compliant cabinet.

For servicing or transportation, the refrigeration cartridge unplugs and lifts off the cabinet. Some minor servicing can be performed without removing the refrigeration cartridge.

The model and serial number are both printed on the cartridge rating/serial number label attached to the top of the side of the cover.

Specifications for the model are in the following table. Verify model and basic requirements before servicing.

Table 17: Cartridge specifications

Cartridge Model	UTHDNI-0043	UTHDNI-0051
Compressor	Embraco VNEU217U	Embraco NTX2213U
Compressor capacity	920 Watts	1250 Watts
Refrigerant / Charge	R290/107 g	R290 / 137 g

Not Cooling Fault

If a customer reports a “not cooling” fault, and it has been established that the cabinet is not cooling, follow the procedure on See “On-site work Procedure” on page 71 when making the service visit.

Removing the Cartridge

Follow the steps below to remove the refrigeration cartridge from the cabinet. Ensure the cabinet is disconnected from the power supply before removing the cartridge.

The cartridge is heavy (single door cartridge 48kg, two door cartridge 58kg) and requires a minimum of two people to lift from the cabinet. Steps or a platform about one metre high are suggested to allow the cartridge to be safely lifted, carried and put down at waist height.

Procedure 10: To remove the refrigeration cartridge

1. Unplug the cabinet from the power supply.
2. Remove the front panel assembly. If fitted with key locks, open the door/s and unscrew the sign from the brackets below the sign.
3. Detach the electronic controller assembly from the top of the cabinet, and clip it onto the top of the cartridge.
4. Remove electrics cover and unplug the mains supply plug and cabinet plugs.
5. **Note:** The cartridge plugs (plugs feeding into the cartridge) and electronic controller plugs (plugs feeding to the electronic controller assembly) do not need to be unplugged.
6. Remove the sign back strip. **Note:** If necessary the sign sides can also be removed.
7. Undo the four cartridge fixing screws (two on each side of the cartridge) and lift the cartridge off the cabinet. Replace seal if damaged because any gap may allow cabinet ice build up.
8. When refitting the cartridge, ensure that:
 - the gasket on the top of the cabinet is in good condition.
 - you take care of cabinet seal: lift the cartridge, do **not** slide cartridge on seal
 - the mains and cabinet plugs are reconnected.
 - you refit the electrics cover.
 - you re-fix the cartridge back in place.

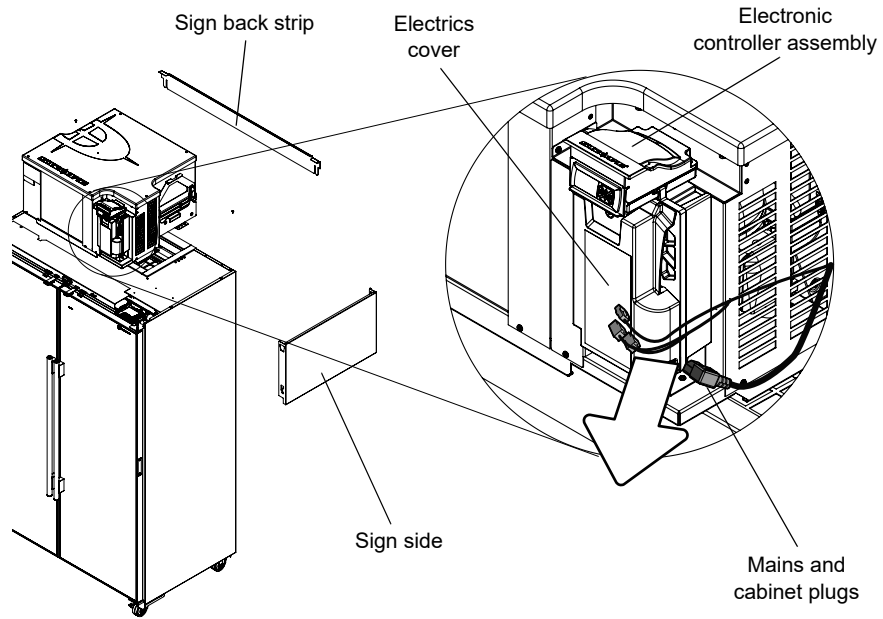

Replacing the Cartridge The SKOPE ActiveCore refrigeration cartridge is interchangeable between bottom and top mount hydrocarbon (R290) ActiveCore chillers.

WARNING
The hydrocarbon cartridge must only be used on a hydrocarbon compliant cabinet.

Procedure 11: To replace a cartridge

1. Check the gasket in the top of the cabinet is in place and in good condition
2. Lift the cartridge into position on top of the cabinet, and reconnect the mains and cabinet plugs
3. Refit the electrics cover and fix in place with the fixing screw.
4. Refit remaining parts, ensuring all fasteners are in place.

Cartridge Electrics Box Assembly The cartridge electrics box assembly contains the mains supply socket, and panel mount socket connectors for the cartridge and cabinet. Refer to the diagram over the page or label on the electrics box cover for socket connection identification.

Due to the confined space within the cartridge electrics box, plugs may come loose as a result of movement and vibrations. Take care when refitting to ensure all plugs are securely attached to the correct sockets.

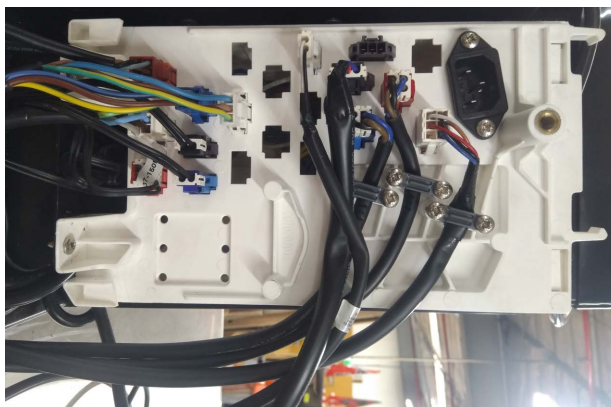

Procedure 12: To remove and open the cartridge electrics box assembly

1. Disconnect the cabinet from the power supply.
 2. Unclip the electronic controller from the top of the electrics box.
-

3. Undo the fixing screw at the top of the electrics box cover, and remove the cover.



4. Unplug all cartridge plugs from the electrics box.
 5. Undo the two fixing screws at the base of the electrics box, and detach the electrics box from the cartridge.
 6. To open the electrics box, undo the two fixing screws on the back of the electrics box and swing the back cover off.
-
-

**Cartridge
Cover Label**

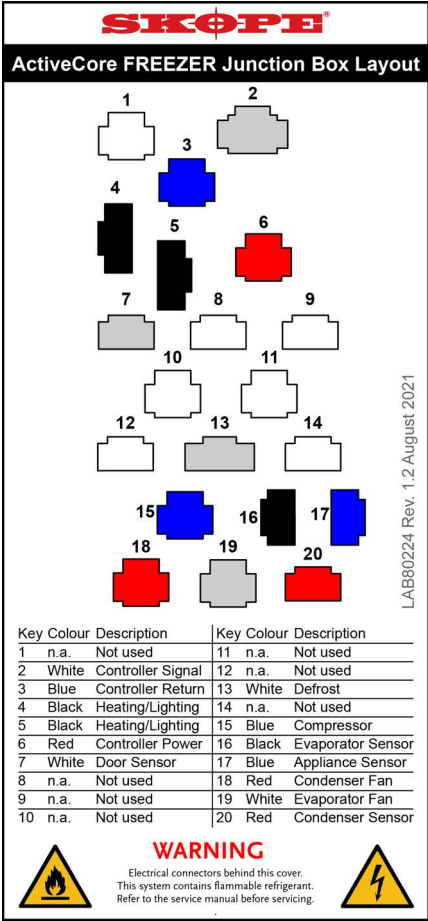

Cartridge cover label for junction box

Cartridge Cover Remove the cartridge cover to access parts within the cartridge assembly.

Procedure 13: To remove the cartridge cover

1. Disconnect the cabinet from the power supply and remove the refrigeration cartridge (see page 48).

2. Unscrew the five screws from the sides of the refrigeration cartridge and lift the cover off the cartridge.



Condenser Fan The condenser fan assembly is made up of a fan motor, fan blade and mounting brackets which can be replaced if necessary.

If the fan stops for any reason, check all connections to ensure no plugs have come loose. Refer to the label on the electrics box cover to identify the condenser fan plug and socket in the electrics box.

IMPORTANT
 Replace the motor with the same SKOPE OEM part.
DO NOT use alternative parts.

It is important that the fan blade and/or fan motor is replaced with the same part to ensure safety, correct alignment and refrigeration performance, and compliance. Fan blades should be tightened to the fan motor manufacturer recommended torque settings (shown in the table below).

Table 18: Fan motor manufacturer recommended torque settings

Fan motor manufacturer	Torque setting
Wellington Drive	1.5 Nm

Procedure 14: To access and remove the condenser fan assembly

1. Disconnect the cabinet from the power supply and remove the refrigeration cartridge (see page 48).
2. Remove the cartridge cover (see page 51).
3. Open the electrics box and unplug the condenser fan motor plug (see page 49).
4. Remove the electrics box to access the condenser fan motor cable, which passes under the electrics box.

5. Cut the cable ties holding the cables along the cartridge, and free up the condenser fan motor cable.



6. Remove the condenser fan assembly (fan motor, fan blade, mounting brackets) from the cartridge by lifting the shroud up and out.



Procedure 15: To replace the condenser fan blade

1. Remove the condenser fan assembly (see above).
2. Remove the screw and washer from the centre of the fan blade, and lift the blade from the motor.
3. Replace new blade and fix with 12 mm flat washer and serrated head screw. Tighten the blade to fan motor manufacturer recommended torque setting 1.5 Nm.
4. Reassemble the cartridge and test.

Procedure 16: To replace the condenser fan motor

1. Remove the condenser fan assembly and the fan blade (see above).
2. Unplug the fan flexible cord from the electrics box (see page 49).
3. Detach the fan motor from the fan mounting brackets by removing the four screws from the mounting bracket.
4. Fit new motor and reattach fan blade with 12 mm flat washer and serrated head screw. Tighten the blade to 1.5Nm. Ensure motor connection plug is orientated to be at the top when fitted.
5. Reassemble cartridge, ensuring all cables are neatly cable tied away from the fan blade, and test for correct operation.

Evaporator Fan The evaporator fan assembly is made up of a fan motor and fan blade, both of which can be replaced when necessary. The evaporator fan flexible cord has a white plug.

If the fan stops for any reason, check all connections to ensure no plugs have come loose. Refer to the label on the electrics box cover (see page 51) to identify the evaporator fan plug and socket in the electrics box.

The fan motor and fan blade are fixed to the evaporator shroud via the brackets. The shroud (complete with fan motor and fan blade) can be lifted off the evaporator tub once the refrigeration cartridge cover and evaporator box top has been removed.

IMPORTANT
 Replace the motor with the same SKOPE OEM part.
DO NOT use alternative parts.

It is important that the fan blade and/or fan motor is replaced with the same part to ensure safety, correct alignment and refrigeration performance, and compliance. Fan blades should be tightened to the fan motor manufacturer recommended torque settings (shown in the table below).

Table 19: Fan motor manufacturer recommended torque settings

Fan motor manufacturer	Torque setting
Wellington Drive	1.5 N m

Procedure 17: To access the evaporator fan assembly

1. Disconnect the cabinet from the power supply and remove the refrigeration cartridge (see page 48).
2. Remove the refrigeration cartridge cover (see page 51).
3. Unclip and remove the foamed top of the evaporator box.

Procedure 17: To access the evaporator fan assembly (continued)

4. Free up cables from the putty on the evaporator box top perimeter has been removed.
5. Cut cable ties to release control probe from the fan bracket.

6. Lift the assembly up and out of the evaporator box.

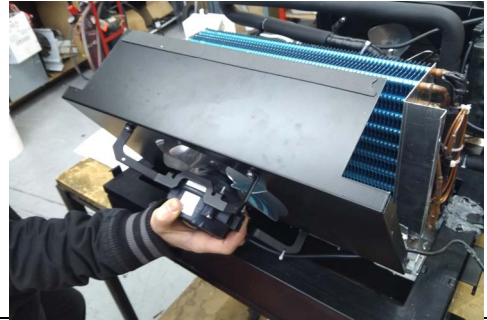

Procedure 18: To replace the evaporator fan blade

1. Disconnect the cabinet from the power supply and remove the refrigeration cartridge (see page 48).
2. Gain access to the evaporator fan assembly (see above).
3. Remove the screw and washer from the centre of the fan blade, and lift the blade from the motor.
4. Fit new blade, ensuring it is centred within the evaporator shroud. Tighten the blade to fan motor manufacturer recommended torque setting 1.5 Nm.
5. Reassemble cartridge and test for correct operation.

Procedure 19: To replace the evaporator fan motor

1. Follow Procedure 17 and Procedure 18 to access the evaporator fan assembly and remove the fan blade.
2. Free the fan's flexible cord by:
 - cutting the cable ties.
 - tracing the cable back to the connector (near the compressor electrics).
 - unplugging the cord.
3. Detach the fan motor from the fan mounting brackets by removing the four screws from the mounting bracket.
4. Attach to the replacement motor. Ensure that the flexible cord points towards the bottom of the evaporator tub once reinstalled. Take care to:
 - re-cable tie the fan and temperature probe flexible cords back onto the mounting bracket (to prevent high frequency vibration).
 - ensure the putty seal is airtight where the flex enters the tub.
5. Ensure the new blade is centred within the evaporator shroud and reattach with a 12 mm flat washer and serrated head screw. Tighten the screw to 1.5 Nm.
6. Reassemble cartridge and test for correct operation:
 - "To determine if there is a sealed system fault" on page 39.
 - Test and tag.

Replacing the Controller

Follow the steps below to replace the controller.

Note: Replacement spare part electronic controllers are not supplied with the parameter set loaded. This must be loaded via the SCS Connect Field app after replacing the controller. Internet access may be required.

Procedure 20: To replace the controller

1. Disconnect the cabinet from the power supply and access the electronic controller (see “Electronic Controller” on page 8).
2. Remove the cable clamps and disconnect the terminals from the back of the controller.

3. Fit the new replacement controller, and connect up the terminals at the back of the controller. Fit low voltage terminals before high voltage terminals.

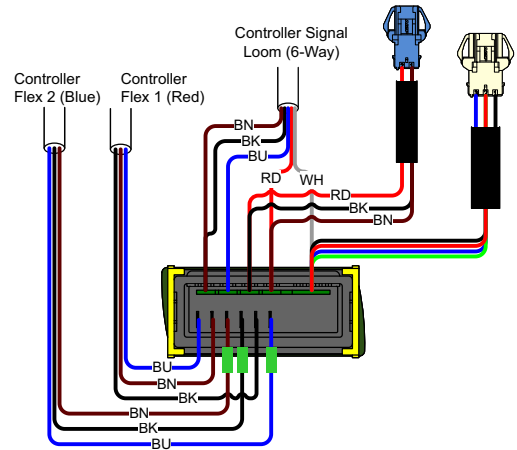

4. Reassemble the controller box and cabinet, perform electrical safety test as required, and reconnect to the power supply.
5. Use a mobile device to connect to the controller with the SCS Connect Field app (see “SCS Connect Field App” on page 10).
6. Navigate to the LOAD PARAMETER FILE menu.
7. Select the appropriate parameter file from LOCAL. If not available in LOCAL, search for the parameter file in SERVER (internet access required), and download to LOCAL.
8. Confirm correct file and WRITE TO SCS.
9. After WRITE TO SCS is complete, select MENU DISCONNECT to save parameter set on SCS.
10. Power cycle the controller and check that correct parameter set has been applied
11. Set up controller and cabinet links as required:

Door Switch The cabinet is fitted with a door switch above the cabinet door(s), which tells the electronic controller when a door is opened. A small magnet in the door frame activates the switch. A cable connects the switch to the electronic controller via an inline connector on top of the cabinet.

Procedure 21: To replace the door switch

1. Disconnect the cabinet from the power supply.
2. Disconnect the door switch cable plug from the inline connector on top of the cabinet.
3. Unscrew the two fixing screws from the door switch and remove.
4. Fit the replacement door switch and connect via the inline connector.

Control Probe The control probe is cable tied to a bracket sitting in the return air port, in front of the evaporator coil.

Procedure 22: To replace the control probe

Before you start

1. If you suspect the probe is faulty, check its calibration using the Probe Resistance table on page 69.
2. Make sure you take note of the original control probe cable's path.

1. Disconnect the cabinet from the power supply (see page 59).
2. Detach the probe from the evaporator fan shroud bracket, trace the probe cable back to the cartridge electrics box, and unplug.

3. Following the same path as the original probe, run the new probe to the original location.

4. Ensure that the:
 - probe cable is securely plugged into the rear of the cartridge junction box, and that it is cable-tied to the evaporator fan shroud bracket, with the probe positioned in a vertical 90° angle.
 - putty seal is airtight where the probe wire enters the evaporation tub.



Control probe

5. Test and tag.
6. Reconnect to power and check operation.

Evaporator Probe The evaporator probe location and its insulation onto the evaporator outlet pipe is critical to reliable function of hot gas defrost and evaporator fan motor function.

IMPORTANT
Ensure the evaporator probe is fully insulated with cork tape at time of replacement

Procedure 23: To replace the evaporator probe

Before you start

1. If you suspect the probe is faulty, check its calibration using the Probe Resistance table on page 69.
2. Make sure you take note of the original evaporator probe's position and probe cable's path.

1. Disconnect the cabinet from the power supply (see page 59).
2. Remove the refrigeration cartridge (see page 48).
3. Remove the cartridge's cover (see page 48).
4. Remove the putty securing the pipes and cables on the evaporator tub perimeter.
5. Carefully lift the coil up and out of the evaporator tub. Take care of pipes and cables when lifting out.
6. Remove the probe from the side of the evaporator coil, and trace the probe cable back to the cartridge electrics box, cutting cable ties as required, and unplug.

Procedure 23: To replace the evaporator probe (continued)

7. Following the same path as the original probe, run the new probe to the evaporator coil and secure with cable ties.

8. Position the probe in the same location as the original probe (against the side of the coil above the bottom pipe).

9. Ensure that the:

- new probe head is insulated to the bottom pipe.
- putty seal is airtight where the probe wire enters the evaporation tub.

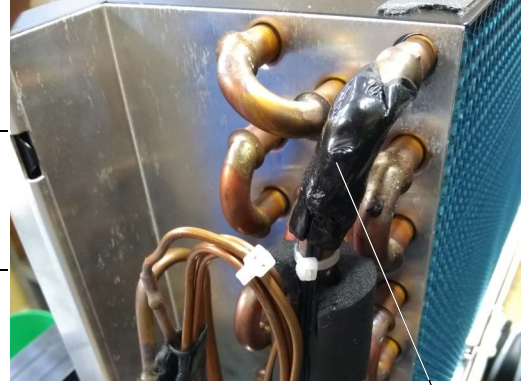

Evaporator probe

10. Plug the probe cable securely into the electrics box.

11. Reassemble the cartridge and test for correct operation:

- “To determine if there is a sealed system fault” on page 39.
- Test and tag.

Condenser Probe The condenser probe is located on the side of the condenser coil. It monitors condenser temperature and protects compressor from overheating.

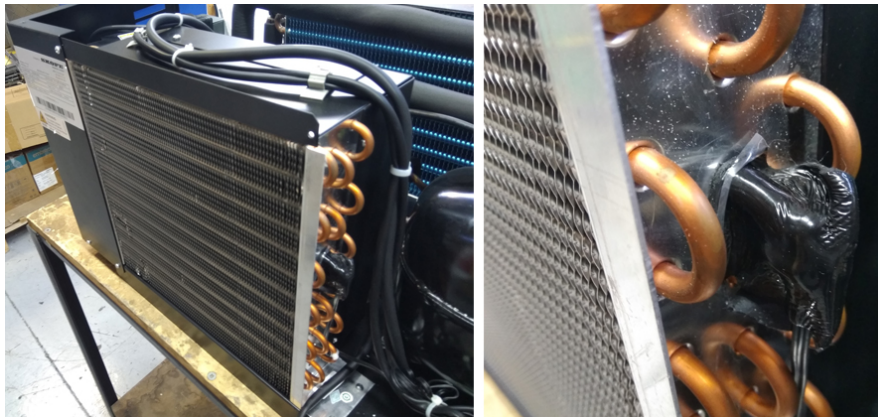
**Procedure 24: To replace the condenser probe**

1. Disconnect the cabinet from the power supply and remove the refrigeration cartridge (see page 48).

2. Remove the top cover, junction box and EMI filter assembly.

3. Detach the probe from the side of the condenser coil, and trace the probe cable back to the cartridge electrics box, cutting cable ties as required, and unplug.

4. Following the same path as the original probe, run the new probe to the condenser coil and secure with cable ties. Locate the probe in the same location as the original probe (as pictured above) and insulate with cork tape. Plug the probe cable securely into the electrics box.

5. Reassemble the cartridge and test for correct operation.

Ambient Probe The ambient probe is located above the controller. It monitors the temperature around the refrigeration cartridge. **Note:** The ambient probe is wired in series with the door switch.



Procedure 25: To replace the ambient probe

1. Disconnect the cabinet from the power supply (see page 59).
 2. Remove front panel assembly, cabinet sides and rear strap.
-

3. Detach the refrigeration cartridge and carefully push back or remove to allow access to the cabinet electrics cover.

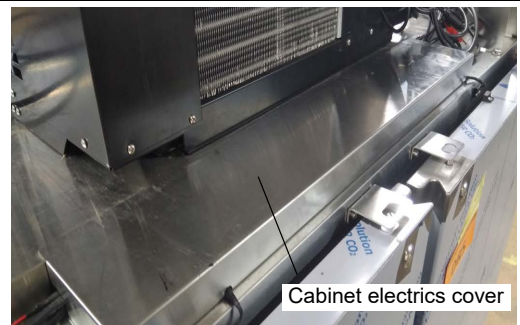

4. Unscrew the cabinet electrics cover.
 5. Detach the probe from the electrics cover, and trace the probe cable back to the connector, cutting cable ties as required, and unplug.
 6. Fit the new probe and secure with cable ties. Ensure the probe is located in the same location as the original probe (as pictured above).
 7. Reassemble the cartridge and test for correct operation.
-
-

Replacing Component Notes

The following refers to replacing compressor and inverter, and any sealed component (evaporator coil / condenser coil)

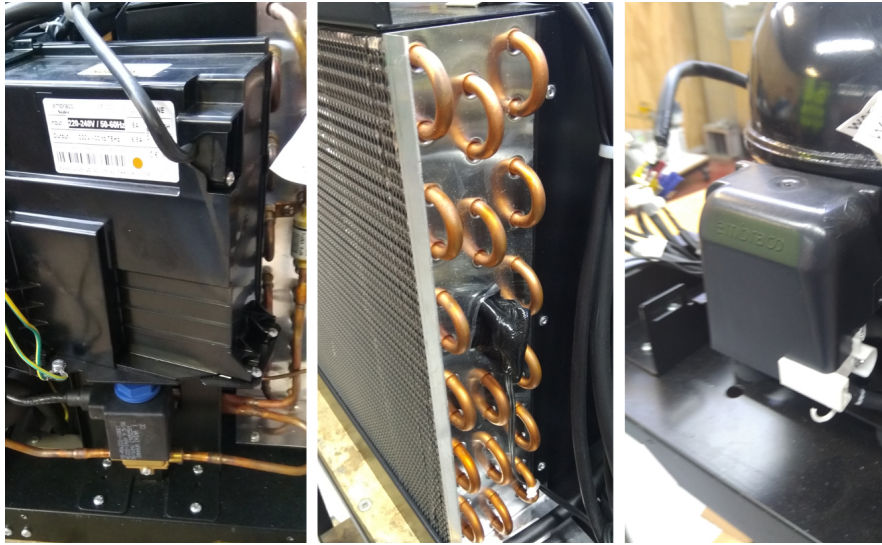

Before replacing the compressor

Check all plug connections and ensure the compressor electrics are operating correctly. The compressor must be supplied with consistent voltage over 220 volts, so ensure the voltage does not drop at start-up. If the voltage does drop, ensure the cartridge has a direct power supply (not from a multi-box or extension cord).

Note that if the compressor is confirmed to be faulty you should also replace the inverter. However if the inverter is faulty, you should not replace a working compressor.

When replacing the compressor

- If you replace a compressor, you should also replace the:
 - compressor thermal protector.
 - inverter.
 - drier.
- Do not leave the compressor or drier open to air – the maximum time allowed is less than 20 minutes.
- Purge the pipes with oxygen-free nitrogen (OFN) at all times when brazing.
- To prove gas tightness, apply a high pressure drop of 1500 Kpa OFN (only) for not less than 12 hours.
- Evacuate to less than 10 Pa for more than 4 hours.
- Charge to ± 1 g of refrigerant charge on label.
- Braze process tubes closed – service valves must not be left on long term.
- Leak test the entire system as final check to confirm that no leaks are present.

Disconnect the Cabinet from the Power Supply

Disconnect the cabinet from the power supply before attempting **any** maintenance.

Procedure 26: To disconnect the cabinet

1. Switch the cabinet off at the mains power supply.
2. Unplug the power cord from the mains power supply.

Lighting

The cabinet is fitted with LED modular interior light(s). Ensure the light is replaced with the same light type. Fluorescent or LED tubes cannot be used in place of LED modular lights.

IMPORTANT
 Replace the light with the same SKOPE OEM part.
DO NOT use alternative LED strip or tube lights, or fluorescent tubes.

Refer to the table below for replacement light specifications.

Table 20: Light specifications

Model	Interior light	
	Description	Part No.
PG21.UPF.1.SD - PP1F	Interior LED light	SKC-2-190-0099-0 - Opaque
PG21.UPF.2.SD - PP2F		

The lighting is made up of three components which are replaceable:

- LED modular light
- Light power supply (1 per cabinet)
- Interior wiring loom (1 per door)

Power is supplied to the lights by the power supply (located in the cabinet electrics panel above the door/s) via the wiring looms which run down through a port on top of the cabinet.

Lighting components are all non serviceable items. If a component is faulty, it should be removed and a SKOPE OEM new replacement component fitted.

Refer to Table 21 below to determine which component may be at fault, and the procedures over the next few pages for component replacement instructions.

Ensure the cabinet is isolated from the power supply before cleaning or removing parts.

Table 21: Lighting fault diagnostics

Problem	Possible Cause	Repair
No lights working. Cabinet is dark.	Lights switched off.	Switch lights on at electronic controller faceplate (see page 9), or the app.
	Controller alarm.	Check controller for alarm code.
	Plug not connected properly.	Check and clean plugs on top of the cabinet.
	Light power supply fault.	Replace light power supply.
Light component not working.	Plug not connected properly.	Check and clean plug connection in side light channel, behind the loom cover.
	Faulty light.	Replace light.
Segment of light not working.	Faulty light.	Replace light.

Procedure 27: To replace an interior LED light assembly

1. Disconnect the cabinet from the power supply.
-

2. Remove all wire shelves from cabinet.
-

3. Shelf support strips will need to be removed on one side of the cabinet. This will depend on if you are replacing a left or right side LED assembly.
-



4. The lighting loom cable will need to be cut when replacing with a new LED light assembly. The lighting cable will need to be reconnected to the lighting socket.
-

5. Under the LED light assembly are five clips which hold the light in place. These clips are positioned at the top and spaced 300 mm down the cabinet wall. Firmly squeeze the light assembly and pull it away from the clip and remove from cabinet.

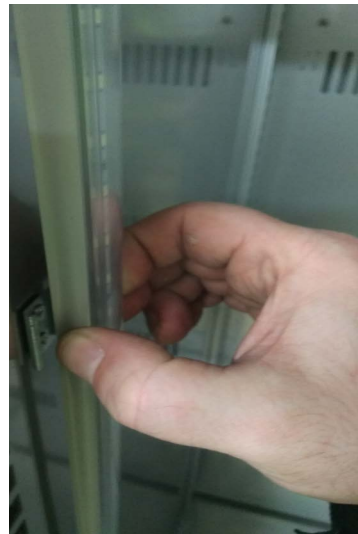

6. Rewire the lighting loom to the socket and connect new LED light assembly
 7. Reattach the LED light assembly and clip into the cabinet
 8. Reconnect to the power supply and check for correct operation.
-

Procedure 28: To replace the LED driver power supply

1. Disconnect the cabinet from the power supply.
2. Remove the front panel assembly, cabinet sides and back strip

IMPORTANT
Lift the cartridge, do NOT slide it, as the cabinet seal may be damaged.

3. The cabinet electrics cover can now be accessed.

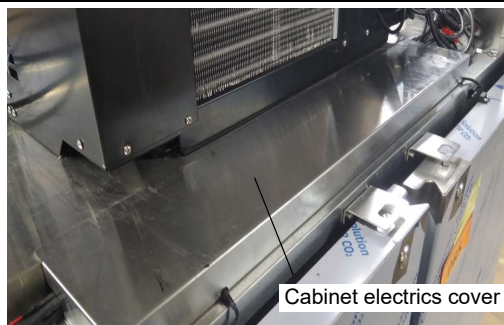

4. Unscrew the cabinet electrics cover.

5. Remove the light power supply.



Check the cabinet top seal is not damaged when refitting the cartridge. Any seal damage must be replaced. Seal damage may result in ice build up in the cartridge.

6. Replace the light power supply and reassemble

Procedure 29: To replace an interior wiring loom

1. Disconnect the cabinet from the power supply.
2. Unplug the light from the wire loom.
3. Gain access to the cabinet electrics panel (see procedure above).
4. Move up to the cabinet roof, and unplug the wiring loom from the light power supply, and if applicable the front panel assembly.
5. Remove the putty from the loom entry point on the cabinet roof, and pull the loom up through the cabinet ceiling.
6. Refit the new loom and reassemble. Ensure:
 - All plugs are clean, correctly fitted and plugged in.
 - That the ceiling and roof hole is completely sealed with putty.

Doors

Door sealing is critical. The gasket must fully sealed around the entire cabinet perimeter because any air gaps will form ice inside the cabinet. This

WARNING
For safe door operation the door bottom hinge bracket must always be fitted with a split pin.

Alignment Adjustment If a door is out of alignment, realign it by loosening the top hinge bracket fixing screws, and move the top of the door as required.

Replacing the Gasket The one-piece door gasket clips into the door frame and runs around the perimeter of the door. Remove the gasket by peeling it from the door frame, starting at a corner.

If the gasket is out of shape after refitting, use a hair dryer to heat and reshape it.

Removing and Refitting the Door For ease of servicing, the door can be removed from the cabinet. Refer to image below for door hinging components.

Procedure 30: To remove the door

1. Disconnect the cabinet from the power supply.
2. Loosen the door locking plate retaining screws.
3. Use an 8 mm socket wrench to take up tension on the capstan lock screw.
4. Remove the door locking plate retaining screws.
5. Remove the tension.
6. Remove the door from cabinet.

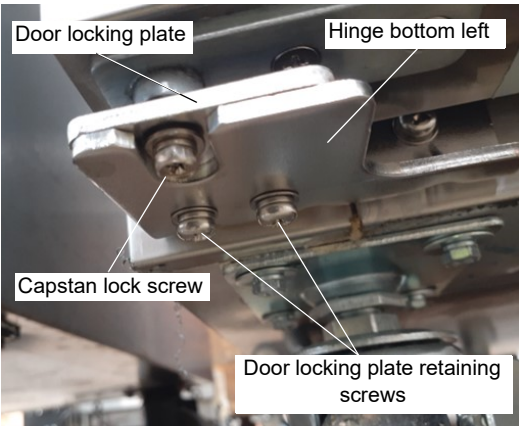

Procedure 31: To replace the top hinge bracket

1. Follow Procedure 30 to remove the door.
2. Remove the top hinge from the top of the door and replace.

Procedure 32: To replace the door

1. Disconnect the cabinet from the power supply.
2. If replacing with a new door, confirm that the door locking plate is located in the correct position.

3. Position the door in top and bottom hinges.

4. Use an 8 mm socket wrench on capstan lock screw to position door locking plate and align mounting holes by rotating door locking plate until holes align. This will apply tension through the capstan to close door.

5. Fit door locking plate and retaining screws.

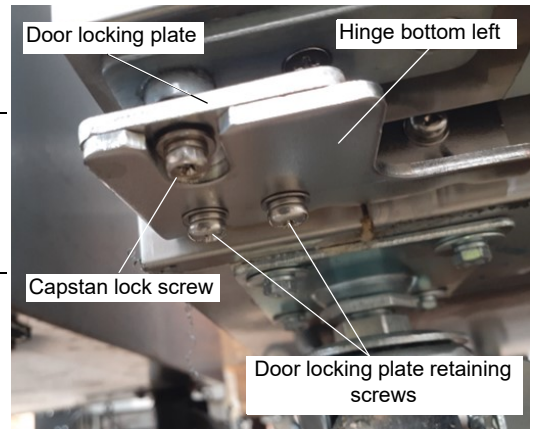

Replacing the Capstan

When the door tension can no longer be adjusted, replace the self closing mechanism.

Procedure 33: To replace the capstan

1. Remove the door from the cabinet (see page 63).

2. Remove 2 × screws from the bottom of the capstan cartridge. Use screw driver tip or metal instrument to pry out the capstan component.

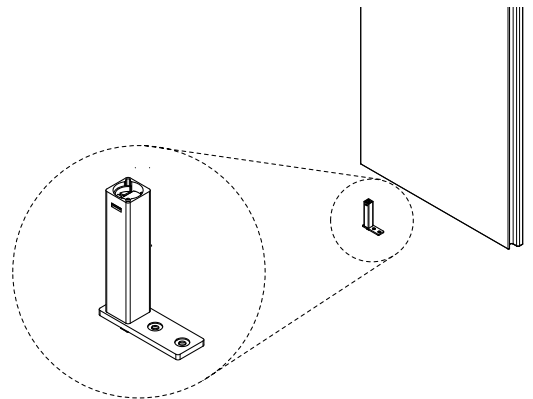

3. Replace with new capstan and fasten with 2 × screws.
4. Refit the door (see page 63).

Cleaning

Cabinet Wipe the inside and outside of the cabinet with a damp cloth, taking care to keep moisture away from electrical parts. As with any maintenance, ensure the cabinet is unplugged from the power supply before cleaning.

Condenser Coil To ensure trouble-free performance, the condenser coil must be kept clean. We strongly urge monthly cleaning with a soft brush to remove dust and fluff. A more thorough cleaning is required by qualified service personnel every six months. The condenser coil **must** be kept clean for efficient and reliable operation.

WARNING
Unplug the cabinet from the power supply before cleaning the condenser coil.

Procedure 34: To clean the condenser coil

1. Disconnect the cabinet from the power supply.

2. Remove the front panel assembly from the top of the cabinet by swinging it out and off. Lit sign front panels will also need to be unplugged.

WARNING: The front panel is heavy, a two person lift is recommended.

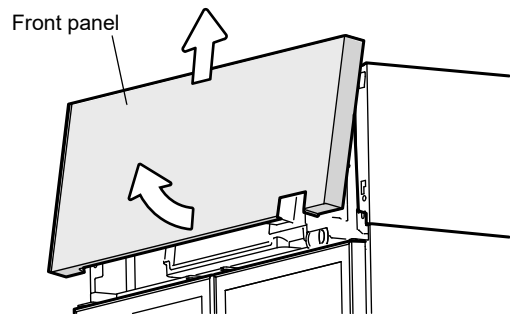

3. Brush the condenser coil with a soft brush to remove any dust and fluff.

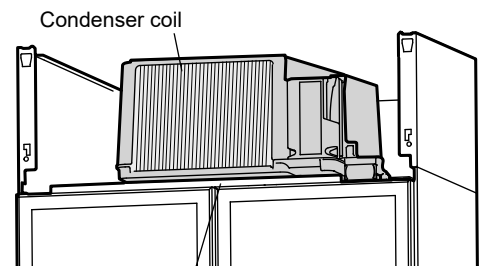

4. Refit the front panel and reconnect to the power supply.

Important

When refitting, ensure the tabs on the back of the sign are located in the notches on top of the cabinet, and that the sign is pushed fully in and secure.

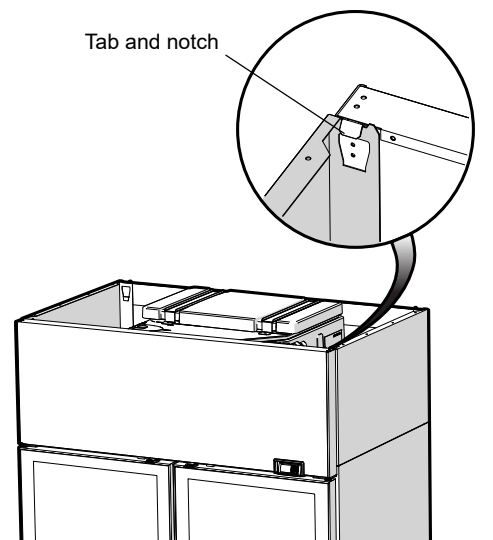

9 Troubleshooting

Electronic Controller

Alarms signal unexpected operational changes in the Freezer. When an alarm is activated, use the electronic controller app to help diagnose the problem, and service as necessary.

Cabinet and Refrigeration Cartridge

For problems with the cabinet and refrigeration cartridge use the following table.

Table 22: Cabinet and cartridge troubleshooting

Problem	Possible Cause	Recommended Action
<ul style="list-style-type: none"> Cabinet not operating No controller display 	<ul style="list-style-type: none"> Loss of power supply Loose plug 	<ul style="list-style-type: none"> Check mains power supply. Check all plugs are connected correctly.
<ul style="list-style-type: none"> Cabinet not operating as usual Defrost cycle incorrect length 	<ul style="list-style-type: none"> Incorrect parameters 	Wellington Drive: Reload the parameter set.
<ul style="list-style-type: none"> Fan not working 	<ul style="list-style-type: none"> Loose plug 	<ul style="list-style-type: none"> Check all plugs are connected correctly.
<ul style="list-style-type: none"> Lights not on 	<ul style="list-style-type: none"> Electronic controller is in "Night" mode Light switched off Failed LED light Refrigeration system error (indicated by the electronic controller) Plug not connected properly Power supply fault 	<ul style="list-style-type: none"> Switch the light on while keeping the cabinet in night mode by pressing the light button on the electronic controller faceplate. Change the cabinet into 'Day mode' by pressing and holding the light button on the electronic controller faceplate, or holding the door open for 10 seconds. Switch the light on via the light button on the electronic controller faceplate, or via the app. Replace the light. Diagnose and repair. If a system fault is found contact SKOPE for information on how to proceed. Check and clean the plugs. Replace the light's power supply.
<ul style="list-style-type: none"> Light component not working 	<ul style="list-style-type: none"> Plug not connected properly Faulty light 	<ul style="list-style-type: none"> Check and clean the plug connection in the side light channel, behind the loom cover. Replace the light.
<ul style="list-style-type: none"> Segment of light not working 	<ul style="list-style-type: none"> Faulty light 	<ul style="list-style-type: none"> Replace the light.
<ul style="list-style-type: none"> Excess noise vibration 	<ul style="list-style-type: none"> Refrigeration pipes transferring vibration into the cartridge 	<ul style="list-style-type: none"> Re-align the pipes to ensure they are not touching the evaporator tub bottom surface, evaporator tub support legs, plastic base, or condenser coil assembly.
<ul style="list-style-type: none"> Excess compressor noise 	<ul style="list-style-type: none"> Noise variation is usual as the variable speed compressor speed changes Damaged mountings 	<ul style="list-style-type: none"> Check the mountings to ensure there is no damage to the rubber, or the washers, nuts or screws.
<ul style="list-style-type: none"> Compressor not operating 	<ul style="list-style-type: none"> Compressor electrics Failed compressor 	<ul style="list-style-type: none"> Check all plug connections and ensure that the compressor electrics are operating correctly. Make sure the compressor is supplied with consistent voltage over 220 volts. Ensure the voltage does not drop at start-up. If the voltage does drop, ensure the cartridge has a direct power supply (not from a multi-box or extension cord) Replace the compressor.

Table 22: Cabinet and cartridge troubleshooting (continued)

Problem	Possible Cause	Recommended Action
• Compressor not operating	• Compressor is disconnected from the inverter	• Verify the compressor cable connection and compressor protector plugs.
	• No control signal input, or bad connection from the controller	• Verify the control input cable connection and measure the signal from the controller.
	• Open compressor winding	• Measure the winding for an open circuit between all pairs of pins on the hermetic terminal. If any winding is open, the compressor is faulty.
	• Compressor has locked rotor, due to mechanical damage	• Replace both the compressor and the inverter.
	• Low input voltage supplied to the inverter	• Measure the AC voltage to confirm.
• Compressor or inverter trips unexpectedly		Wait for it to cool and reset: <ul style="list-style-type: none"> • Inverter: 1 to 10 minutes. • Compressor protector: 60 minutes.
• Frozen evaporator coil	• Evaporator probe fault	• Replace the evaporator probe.
	• Setpoint is too cold	• Check and raise the setpoint.
	• Controller fault	• Replace the controller.
	• Short of refrigerant	• Perform refrigeration system diagnostics and service as required.
• Ice build-up inside evaporator box	• Leaking cartridge seal	• Check that the evaporator tub seals are fully clamped, and the cabinet top seal is good without gaps. Micro-gaps will allow ice build-up in the cabinet.
• Power consumption is higher than expected	• Cabinet door is opened too often	• Ensure the door is closed more often.
	• Cartridge is operating too hot	<ul style="list-style-type: none"> • Clean the condenser. • Ensure the cabinet has good ventilation around the refrigeration cartridge. • Ensure the cabinet is within the maximum operating temperature.
	• Product is too cold	• Raise the setpoint.
• Product is too warm	• Door not closing properly	• Check and clean the door gasket.
	• Excessive door opening	• Limit door openings.
	• Electronic controller is in “Night” mode	• Change the cabinet into “Day” mode by pressing and holding the light button on the electronic controller faceplate, or holding the door open for ten seconds.
	• Refrigeration system error (no active fault alarm)	• Check the SCS Connect Field app statistics to see if and when the controller signalled a fault or alarm.
	• Cartridge is operating too hot	• Ensure the cabinet has good ventilation around the refrigeration cartridge.
	• Excessive refrigeration heat load	• Ensure the cabinet is within the maximum operating conditions.
	• Setpoint is too high	• Lower the setpoint.
	• Recently loaded	• Allow the product time.
	• Cabinet is overstocked	<ul style="list-style-type: none"> • Remove some product. • Product must not overhang the shelves, and must remain below load limit label.
	• Refrigeration system error (indicated by the electronic controller)	• Diagnose and repair. If a system fault is found contact SKOPE for information on how to proceed.
• Moisture build up on cabinet exterior	• Frequent door opening	• Limit door openings.
	• Door not closing properly	• Check and clean the door gasket.
	• High humidity	• Check the ambient operating temperature and reposition the cabinet if necessary.

Table 22: Cabinet and cartridge troubleshooting (continued)

Problem	Possible Cause	Recommended Action
<ul style="list-style-type: none"> • Cabinet door does not close properly 	<ul style="list-style-type: none"> • Cabinet is on an uneven surface 	<ul style="list-style-type: none"> • Level the cabinet.
	<ul style="list-style-type: none"> • Door is obstructed 	<ul style="list-style-type: none"> • Check the shelves and product.
	<ul style="list-style-type: none"> • Door gasket is dirty 	<ul style="list-style-type: none"> • Check and clean the door gasket.
<ul style="list-style-type: none"> • Warm cabinet temperatures • Compressor operating for long periods (more than 1 hour) 	<ul style="list-style-type: none"> • Blocked condenser coil 	<ul style="list-style-type: none"> • Clean the condenser coil.
	<ul style="list-style-type: none"> • Poor ventilation around refrigeration cartridge 	<ul style="list-style-type: none"> • Ensure the cabinet has good ventilation around the refrigeration cartridge. • Ensure the cabinet is within the maximum operating temperature.

Probe Resistance

Product specification

产品技术规格

规格型号(PART NO.)	APR-CWF103F3435FB3000B
文件编号(FILE NO.)	APR-CWF9573A
版本(EDITION)	A/2

MF58D R25=10.000K Ω \pm 1% B25/85= 3435K 料号: BT07D 版本: A							
T(°C)	Rmin(K Ω)	Rnom(K Ω)	Rmax(K Ω)	T(°C)	Rmin(K Ω)	Rnom(K Ω)	Rmax(K Ω)
-40	202.879	211.276	219.999	-3	31.143	31.824	32.516
-39	191.348	199.150	207.250	-2	29.784	30.422	31.069
-38	180.601	187.855	195.381	-1	28.492	29.089	29.695
-37	170.571	177.320	184.317	0	27.264	27.823	28.390
-36	161.198	167.481	173.991	1	26.097	26.620	27.150
-35	152.430	158.281	164.340	2	24.986	25.475	25.972
-34	144.217	149.669	155.312	3	23.929	24.387	24.852
-33	136.518	141.601	146.858	4	22.923	23.352	23.787
-32	129.293	134.033	138.933	5	21.966	22.367	22.774
-31	122.508	126.930	131.499	6	21.055	21.430	21.810
-30	116.130	120.257	124.518	7	20.187	20.538	20.893
-29	110.131	113.983	117.959	8	19.360	19.688	20.020
-28	104.484	108.081	111.792	9	18.572	18.879	19.189
-27	99.164	102.525	105.988	10	17.821	18.108	18.398
-26	94.151	97.291	100.525	11	17.105	17.373	17.644
-25	89.424	92.358	95.378	12	16.422	16.673	16.926
-24	84.963	87.706	90.527	13	15.770	16.005	16.241
-23	80.753	83.316	85.953	14	15.149	15.368	15.588
-22	76.777	79.174	81.637	15	14.556	14.760	14.966
-21	73.020	75.261	77.564	16	13.989	14.180	14.372
-20	69.469	71.565	73.717	17	13.449	13.627	13.806
-19	66.111	68.072	70.084	18	12.932	13.098	13.265
-18	62.935	64.769	66.651	19	12.439	12.593	12.749
-17	59.929	61.646	63.405	20	11.967	12.111	12.256
-16	57.084	58.690	60.336	21	11.516	11.650	11.785
-15	54.391	55.894	57.432	22	11.085	11.210	11.335
-14	51.839	53.246	54.685	23	10.672	10.788	10.905
-13	49.422	50.738	52.085	24	10.278	10.386	10.493
-12	47.131	48.363	49.623	25	9.900	10.000	10.100
-11	44.959	46.113	47.291	26	9.531	9.631	9.731
-10	42.899	43.979	45.082	27	9.178	9.278	9.378
-9	40.946	41.957	42.989	28	8.841	8.940	9.039
-8	39.093	40.039	41.004	29	8.517	8.616	8.715
-7	37.334	38.220	39.123	30	8.207	8.306	8.404
-6	35.664	36.494	37.339	31	7.911	8.008	8.106
-5	34.079	34.856	35.647	32	7.626	7.723	7.821
-4	32.573	33.301	34.041	33	7.354	7.450	7.546

Product specification

产品技术规格

规格型号(PART NO.)	APR-CWF103F3435FB3000B
文件编号(FILE NO.)	APR-CWF9573A
版本(EDITION)	A/2

MF58D R25=10.000K Ω \pm 1% B25/85= 3435K 料号: BT07D 版本: A							
T(°C)	Rmin(K Ω)	Rnom(K Ω)	Rmax(K Ω)	T(°C)	Rmin(K Ω)	Rnom(K Ω)	Rmax(K Ω)
34	7.092	7.188	7.283	71	2.103	2.157	2.212
35	6.841	6.936	7.031	72	2.041	2.095	2.149
36	6.601	6.694	6.789	73	1.982	2.034	2.088
37	6.370	6.463	6.556	74	1.925	1.976	2.029
38	6.148	6.240	6.332	75	1.870	1.920	1.972
39	5.936	6.026	6.117	76	1.816	1.866	1.916
40	5.731	5.820	5.911	77	1.765	1.813	1.863
41	5.535	5.623	5.712	78	1.715	1.763	1.811
42	5.346	5.433	5.521	79	1.667	1.714	1.762
43	5.164	5.250	5.337	80	1.620	1.666	1.713
44	4.990	5.075	5.160	81	1.575	1.620	1.667
45	4.822	4.906	4.990	82	1.532	1.576	1.621
46	4.660	4.743	4.826	83	1.489	1.533	1.578
47	4.505	4.586	4.668	84	1.449	1.492	1.535
48	4.355	4.435	4.516	85	1.409	1.451	1.494
49	4.211	4.290	4.370	86	1.371	1.412	1.455
50	4.072	4.150	4.228	87	1.334	1.375	1.416
51	3.939	4.016	4.093	88	1.298	1.338	1.379
52	3.811	3.886	3.962	89	1.264	1.303	1.343
53	3.688	3.762	3.837	90	1.230	1.269	1.308
54	3.569	3.642	3.716	91	1.198	1.235	1.274
55	3.455	3.526	3.599	92	1.166	1.203	1.241
56	3.345	3.415	3.487	93	1.136	1.172	1.209
57	3.239	3.308	3.378	94	1.106	1.142	1.179
58	3.137	3.205	3.274	95	1.078	1.113	1.149
59	3.039	3.106	3.174	96	1.050	1.084	1.120
60	2.944	3.010	3.077	97	1.023	1.057	1.092
61	2.853	2.918	2.983	98	0.997	1.030	1.064
62	2.765	2.829	2.893	99	0.971	1.004	1.038
63	2.681	2.743	2.806	100	0.947	0.979	1.012
64	2.599	2.660	2.723	101	0.923	0.955	0.987
65	2.520	2.580	2.642	102	0.900	0.931	0.963
66	2.444	2.503	2.564	103	0.878	0.908	0.939
67	2.371	2.429	2.488	104	0.856	0.886	0.916
68	2.300	2.357	2.416	105	0.835	0.864	0.894
69	2.232	2.288	2.345				
70	2.166	2.221	2.278				

On-site work Procedure

If a customer reports a “not cooling” fault, and it has been established that the cabinet is not cooling, follow the procedure for an authorised service person below when making the service visit.

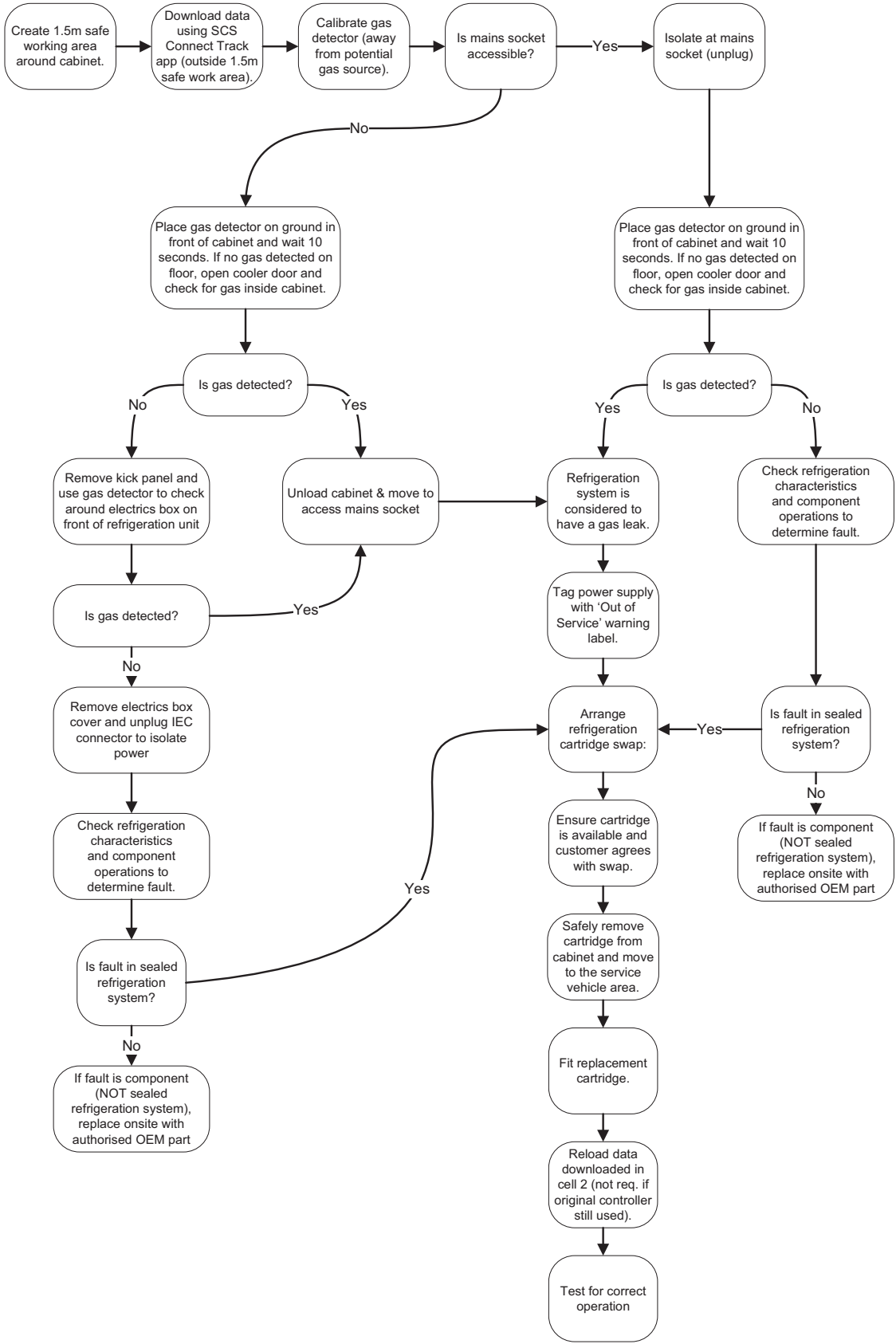

On-site work procedure (continued)

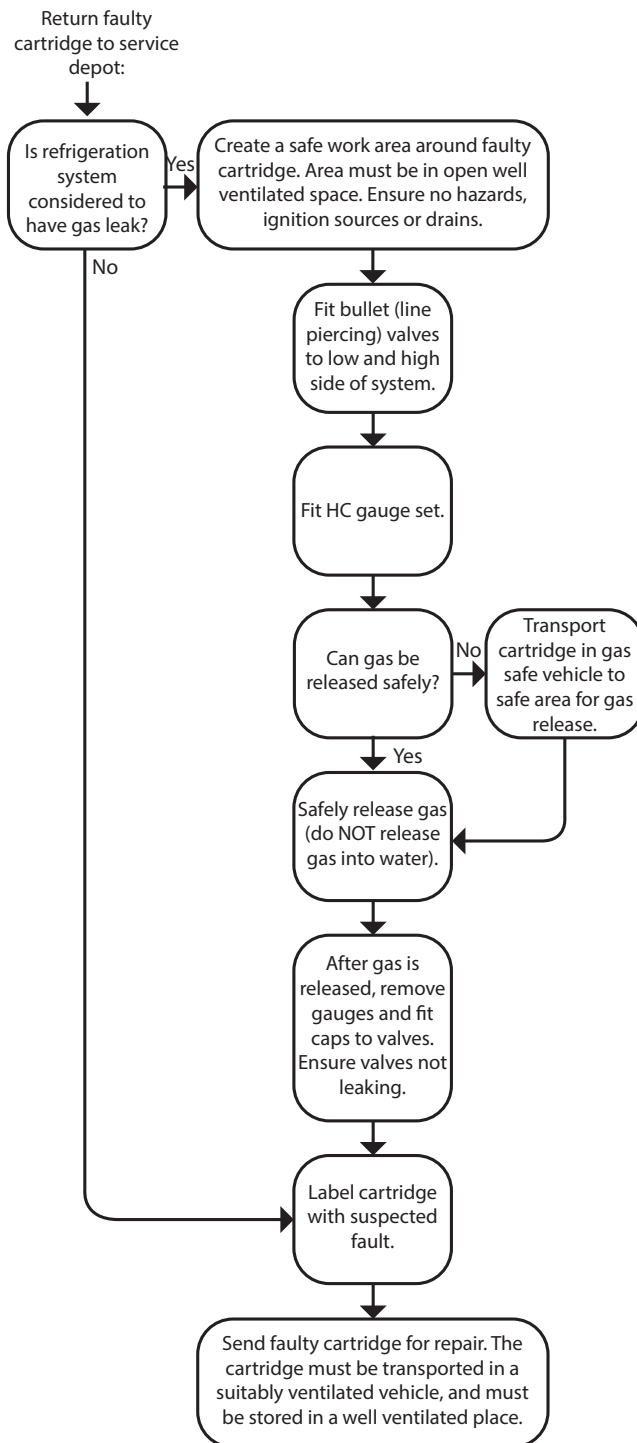

SKOPE Contacts

SKOPE Industries Limited

ABN: 73 374 418 306

AU: 1800 121 535

NZ: 0800 947 5673

skope@skope.com

www.skope.com