

## Two Solid Door Freezer, Unlit Sign, No Internal Lighting

Range: ActiveCore Freezer

SKOPE ID: LT10SZN

Dimensions: 1130 mm (W) × 695 mm (D) × 2210 mm (H)

Capacity: 896 L

Project: \_\_\_\_\_

Item #: \_\_\_\_\_



A high-efficiency, top-mounted heavy duty display or storage freezer suitable for both front and back of house applications. By using natural refrigerants and inverter technology the freezer achieves high performance with low energy consumption. This model has solid doors, an unlit sign and no internal lighting. It has customisable additional shelving, different locks, or specialised ICE storage. With L1 compliance it is engineered to serve frozen food at a standard -18°C to -21°C and is adjustable from -12°C to -26°C. It is certified under GEMS to climate class 4 and is fully tested to operate in ambient environments of up to 40°C (climate class 5). The refrigeration cartridge can be fully removed in line with best practice for safe servicing of flammable refrigerants. The cabinet includes a controller that connects to the free SKOPE-connect app to enable you to set temperatures and alerts, monitor temperatures and energy, and more. The freezer is certified to all Australian and New Zealand refrigeration and electrical safety standards.



Warranty



ActiveCore Technology



Natural Refrigerant



GEMS



SKOPE-connect

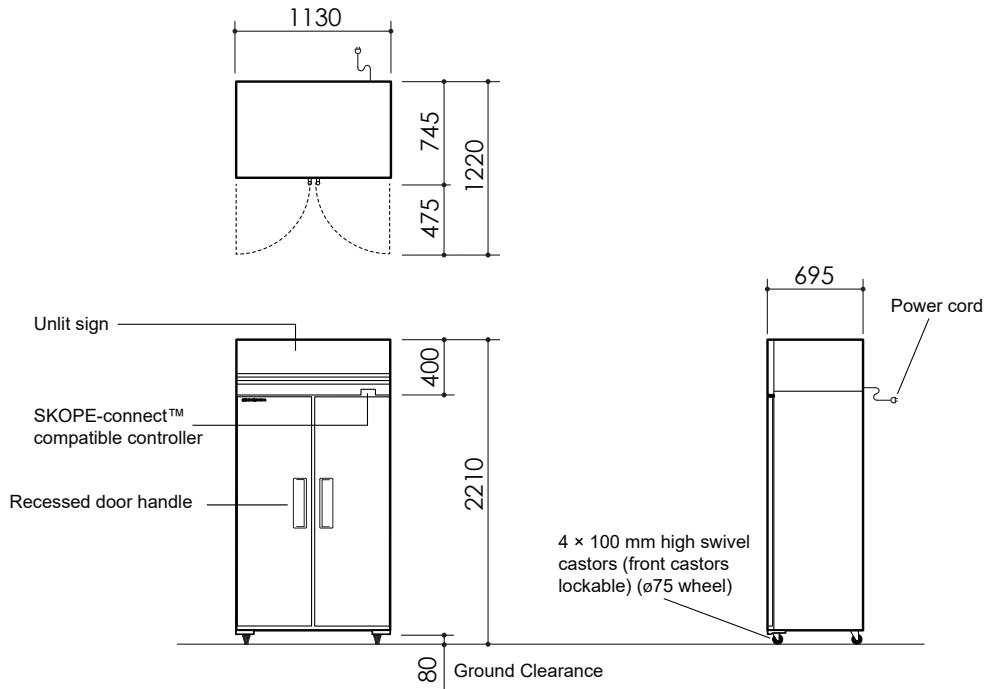

### Cabinet

<b>Type</b>	SKFT Freezer		
<b>Finish</b>	Stainless steel or powder-coated galvanised steel with optional colours from within the available SKOPE range		
<b>Insulation</b>	Type	PU foam	
	Thickness (mm)	50	
<b>Doors</b>	Blowing Agent	Cyclo-iso pentane (C5H10/C5H12)	
	Type	Solid swing door	
<b>Doors</b>	Opening Size	Height (mm)	1570
		Width (mm)	436
<b>Shelving</b>	Ten adjustable height plastic-coated wire shelves 10 x half width shelf (502W x 467D)		
<b>Lighting</b>	Sign	n.a.	
	Interior*	None	

### Dimensions†

	External	Internal	Packed
Width (mm)	1130	1030	TBC
Depth (mm)	695	554	TBC
Height (mm)	2210 (castors)	1570	TBC
Weight (kg)	TBC		TBC
Capacity (L)	896		
Footprint (m <sup>2</sup> )	0.79		

### Ventilation (mm)

Top	300	Sides	Not required	Rear	10
-----	-----	-------	--------------	------	----

### Dimensional Tolerances

† Allow for dimensional tolerances when installing the cabinet(s).

Linear dimensions	Single cabinet	Multiple cabinets	
		At each joint	At each end wall
Less than 1 metre	±5 mm	±5 mm	+15 mm
More than 1 metre	-5 mm to +10 mm	-5 mm to +10 mm	+15 mm

### Performance

<b>Product Temperature Range (°C)</b>	-18 to -21 (adjustable* from -12 to -26)	
<b>Maximum Ambient Temperature (°C)</b>	40	
<b>Sound Level (dB(A))</b>	Standard	62.9
	Hush Mode*	61.7

### Greenhouse and Energy Minimum Standards (GEMS)

<b>Star Rating</b>	2	
<b>Product Temperature Class</b>	L1 (less than -18°C)	
<b>Total Energy Consumption</b>	11.35 kWh/24 h	
<b>Annual Running Costs</b>	\$1243 (@ \$0.30/kWh)	

### Electrical

<b>Supply</b>	220-240 volts a.c., 50 Hz, single phase supply	
<b>Cord</b>	2 m power cord with 3-pin, 10 amp plug	
<b>Current draw (A)</b>	5.5	

### Refrigeration

<b>Controller</b>	SCS Connect (SKOPE-connect™ compatible)		
<b>System Type</b>	Removable cartridge		
<b>Cartridge Weight (kg)</b>	47.5		
<b>Refrigerant/Charge</b>	R290/107 g		
<b>Nominal Capacity (W)</b>	1097		
<b>Heat Rejection (W)</b>	Average	475	Peak 600
<b>Defrost Type</b>	Hot gas		
<b>Drainage</b>	No plumbing required		

\* Accessible via the free SKOPE-connect™ app.



SKFT1000NS-A  
on the SKOPE website

