



REFRIGERATION

HOT ISLAND MERCHANDISER

HOT DISPLAY CASE



HOT



MEALS



PLUG-IN

FEATURES INCLUDE

- Hexagonal with 2 display levels
- Horizontal heated shelves
- Stainless steel finish
- Halogen lighting
- Individual temperature adjustment to each shelf level



Scan here to check for Energy Efficiency Rebates in your state.

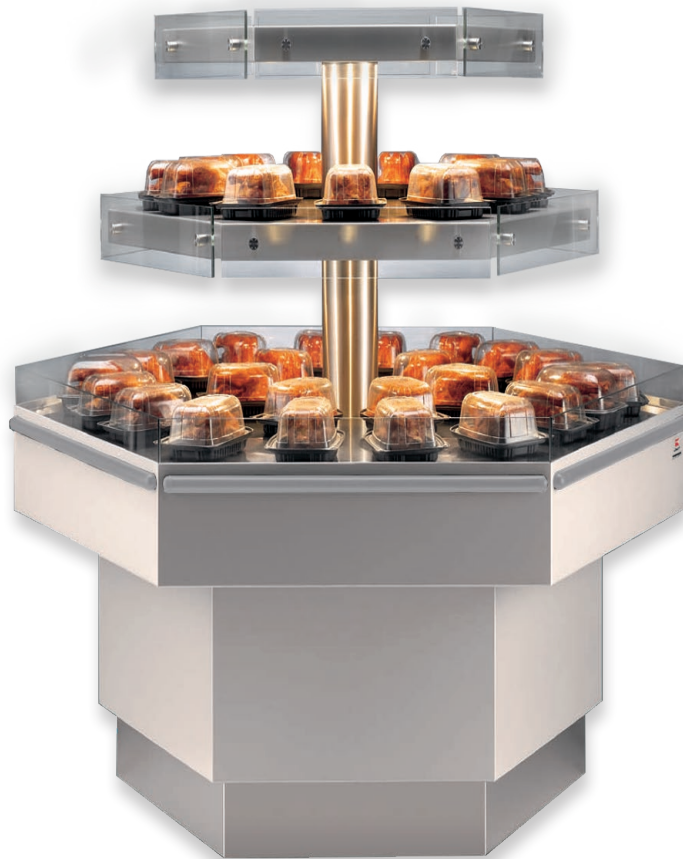

Product image not to scale



REFRIGERATION

HOT ISLAND MERCHANDISER

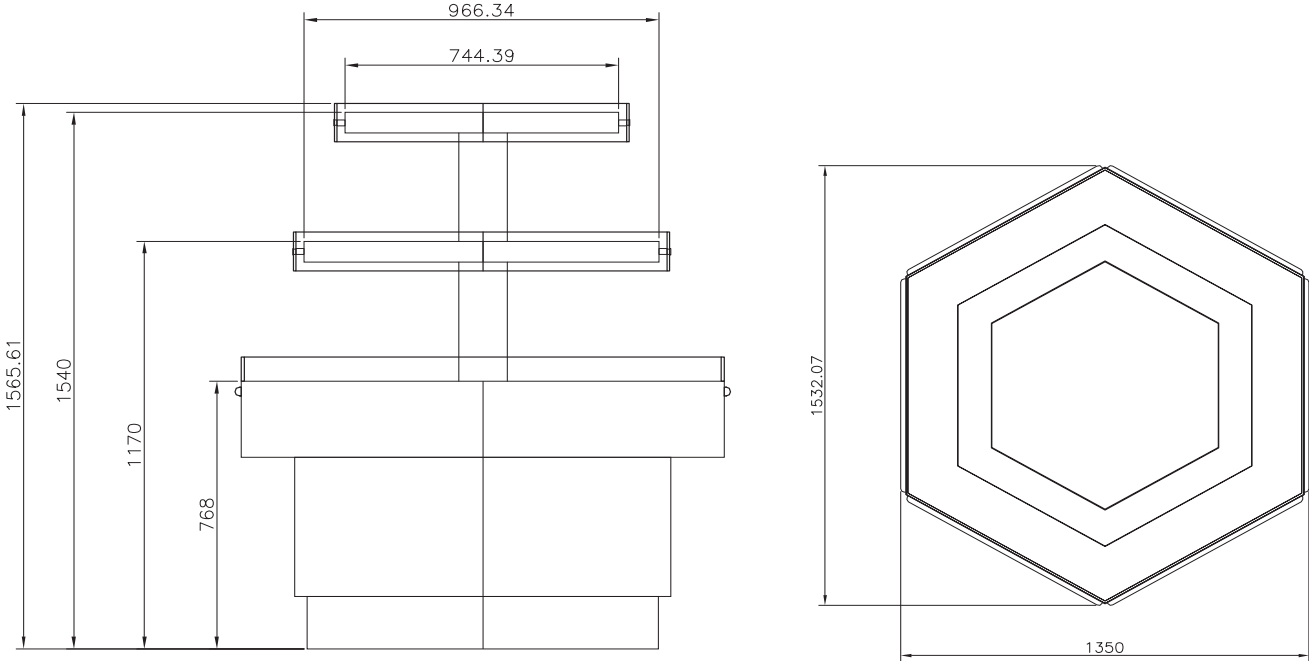

HIM-S	
OPERATING TEMP (°C)	+65
POWER SUPPLY	415V/3ph+N/hard wire
OPERATING CURRENT (Amp)	14.2
NOMINAL POWER (W)	10200
ENERGY CONSUMPTION (kWh/24h) / 12hr	122
LENGTH (mm)	1350
HEIGHT (mm)	1565
DEPTH (mm)	1530
WEIGHT WITHOUT PACKAGING (kg)	240

