

GS⁶³⁰ | SMALL BUT MIGHTY.

The smallest utensil washer in the world





THE SMALL MODEL FOR HEAVY DUTY.

It takes up hardly any space in the kitchen. But it packs quite a punch. With its high water pressure, it cleans away even stubborn dirt, leaving your utensils hygienically clean. No matter what comes its way. Trays, GN containers, Euronorm crates. Trays and filters. The GS 630 can do it all. In bakeries and butcher's shops. In the catering industry and chain restaurants.

PERFECT CLEANLINESS AND HYGIENE

Wherever utensils are in use, cleanliness and hygiene are the top priority. In the GS 630, a reversing wash system works with a wash arm at top and bottom. They follow one quickly after the other in opposite directions, thereby achieving maximum coverage and mechanical effect. This also ensures perfect wash results even with heavy soiling.

EXTREMELY EASY TO USE

With the short, standard and intensive programmes, the wash cycle can be adapted easily and quickly to the level of soiling. Straightforward features: the start button with single-button operation is language-neutral and colour-coded. The current tank and boiler temperature as well as the detergent and rinse aid fill levels can be easily read from the display. The detent position for the door ensures that the interior of the machine is ventilated at the end of the working day. Perfect!

HIGH QUALITY AND RESILIENT

Materials and finishing of the highest quality, an automatic self-cleaning programme and components that can be removed easily for manual cleaning: the GS 630 is designed for a long service life. Typical of Winterhalter.

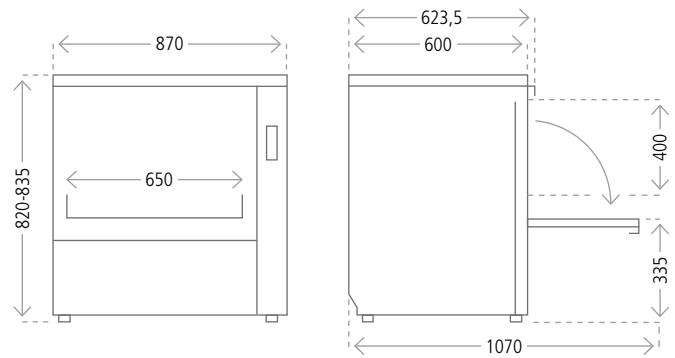

TECHNICAL DATA

General data		GS 630
Tank capacity	l	25
Rack dimensions	mm	600 x 465
Clear entry height		
– without rack	mm	410
– with rack		400
Clear entry width	mm	650
Wash pump	kW	1.5
Noise emission	dB(A)	< 70
Splash guard		IPX5
Weight net / gross	kg	105 / 120
Max. inlet water temperature	°C	60
Required water flow pressure		
– without cold water pre-wash	bar / kPa	1.0 – 6.0 / 100 – 600
– with cold water pre-wash		2.5 – 6.0 / 250 – 600
Specific data		
Theoretical capacity *1	Racks / h	38 / 29 / 12
Rinse water consumption per wash cycle *2	l	4.4
Tank temperature	°C	60
Rinse water temperature	°C	85 (65) *3

ELECTRICAL DATA

Voltage	Fuse protection
380V – 415V, 3N~, 50 Hz / 60 Hz	16A
230V, 3~, 50 Hz / 60 Hz	20A
200V, 3~, 50 Hz / 60 Hz	25A
Total connected load	
Tank heating 4.9 kW *4 / 5.3 kW *4	
Boiler heating 4.9 kW *4 / 5.3 kW *4	
7.1 kW	Worldwide
6.6 kW	Belgium
6.6 kW	Japan

*1 Depending on local conditions (inlet water temperature / electrical supply), the values stated here may be reduced.

*2 Non-binding information. The actual rinse water consumption may vary depending on the on-site conditions.

*3 Optional temperature switching.

*4 The actual power varies depending on the mains voltage.