

Model  
**EVEREO®**

- Food preserver
- Electric
- 10 trays 460x330
- Drop-down door opening
- 7" Touch control panel



## DESCRIPTION

Service Temperature Food Preserving is a patented technology that has been designed to preserve food at the temperature at which it is served and eaten. It means that you can cook food, keep it hot without blast freezing and regenerating it, and serve it in a few seconds at any time of the day and with zero waiting time for your customers. With only 600 mm deep, the EVEREO® CUBE is the compact solution for quick installations in small spaces and outside the kitchen area. The EVEREO® CUBE easily fits any business and is available with left or right door opening. The wide glass and the LED light allow maximum visibility of the products while the compact size allows you to quickly identify the products to be served without taking out the trays.

## STANDARD COOKING FEATURES

### Settings

- **Temperature:** 58 °C – 75 °C
- **Automatic program set:** possibility to select the food to be preserved in the pre-loaded program list and automatically regeneration time, preserving temperature and time will be set up for you
- **Tray assignment:** possibility to assign one preserving program to a dedicated tray
- **MULTI.Time list:** technology to manage up to 06 timers to preserve different products at the same time
- **ROP:** manage the programs Reorder Point (the minimum number of sous-vide single portions that must always be present in your chamber) in order to not run out during service of your best selling menu items
- **CLIMA.Control:** humidity or dry air set by 10%

### Programs

- Store up to 256 users programs
- **MULTY.DAY MODE:** choose or set the program that is more suitable to preserve your food for days or weeks in sealed containers
- **SUPERHOLDING MODE:** set your personal programs while using open containers or trays, and have your food held at the precise temperature
- **MEALME MODE:** you will be able to use the programs to be used with the food that you have ordered by any of our MEALME approved vendors

## STANDARD TECHNICAL FEATURES

- High-resistance AISI 304 stainless steel cavity with rounded edges
- Double glass
- Cavity lighting through LED lights embedded in the door
- Tray supports with anti-tipping system
- Fan impeller brake to contain energy loss at door opening
- Safety temperature limiter

## ADVANCED AND AUTOMATIC COOKING FEATURES

### Air distribution in the preserving chamber

- **AIR.Maxi™:** airflow speed management intelligently redistributed

### Temperature control

- Latest generation sensors allow to set up EVEREO® with a certainty of a degree of precision of 0.5 °C

### Thermal insulation and safety

- **Protek.SAFE™:** maximum thermal efficiency and working safety (complies with the IEC/EN60335-2-42 rule)

## APP & WEB SERVICES

- mealmefood.com



# XEEC-10HS-EPD

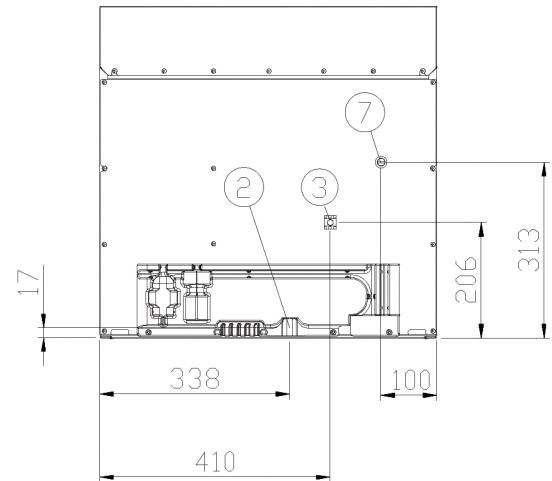
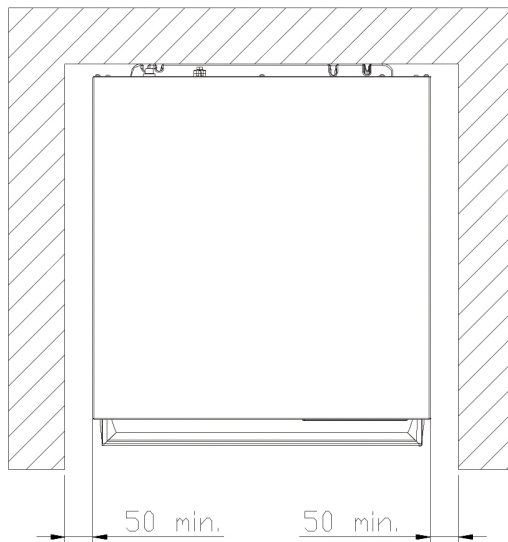
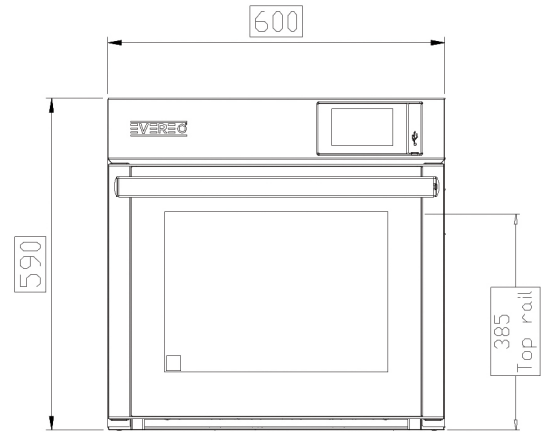
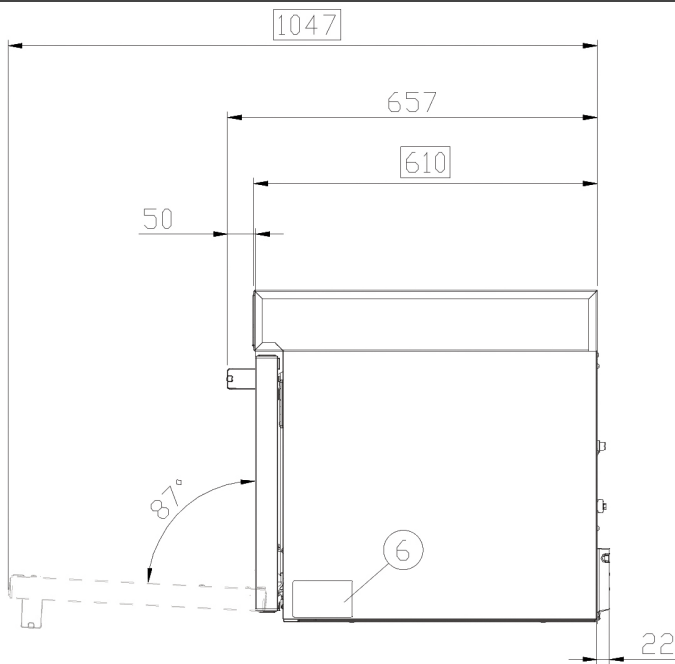

## DIMENSIONS AND WEIGHT

Width	600 mm
Depth	632 mm
Height	590 mm
Net Weight	47,5 kg
Pan spacing	28 mm

## CONNECTION POSITIONS

- |   |                             |
|---|-----------------------------|
| 2 | Terminal board power supply |
| 3 | Unipotential terminal       |
| 6 | Technical data plate        |
| 7 | Safety thermostat           |

# XEEC-10HS-EPD

## POWER AND GAS SUPPLY

### STANDARD

Voltage	220-240 V
Phase	1PH+PE
Frequency	50-60 Hz
Total power	1.5 kW
Maximum Amp Draw	6,5 A
Required breaker size*	16 A
Power cable requirement	H07RN-F 3G 1.5 mm <sup>2</sup>
Cord diameter	10 mm
Plug	Schuko

## ACCESSORIES

- **Preserving Essentials:** special trays
- **Wi-Fi:** Connection board to keep the oven connected to UNOX cloud mandatory to extend warranty
- **SPRAY&Rinse:** Pratico detergente spray per la pulizia manuale di qualunque forno. Sgrassa ed elimina ogni tipo di sporco

## INSTALLATION REQUIREMENTS

Installations must comply with all local electrical systems, particularly as for minimum wire gauge required for field connection, hydraulic and ventilation supply. Exhaust and fume analysis must be performed in case of gas ovens.

Register to access data and product specifications  
[infonet.unox.com](http://infonet.unox.com)

