



## S120E

Modular electric oven for bakery

COMPOSITION WITH 2 BAKING CHAMBERS  
INTERNAL HEIGHT 30cm



### OPTIONS AND ACCESSORIES

- Leavening prover on wheels, height 800mm
- Leavening prover on wheels, height 600mm
- Support with wheels, height 600mm
- Support with wheels, height 800mm
- Steamer for baking chamber
- Refractory brick cooking surface
- Additional tray holder guides for compartment and support
- Motor for hood vapours extraction 500 m<sup>3</sup>/h
- Lateral tool-holder for compartment

### EXTERNAL CONSTRUCTION

- Structure made in folded stainless steel
- Side panels in pre-painted sheet metal
- Channel hood
- Front vapour collection hood in stainless steel sheet with tempered silk-screen printed glass logo
- Steam duct in stainless steel plate
- Stainless steel door with bottom hinge and spring balance, tempered glass element
- Door handle in stainless steel

### INTERNAL CONSTRUCTION

- Cooking surface in buckle plate
- Aluminated steel top and side structure
- Dual halogen lighting
- Rock wool heat insulation

### FUNCTIONING

- Heated by highly performing armoured heating elements
- Temperature management using P.I.D. (Proportional Integrative Derivative) permit the automatic energy regulation to the quantity of the baked product ADAPTIVE-POWER® TECHNOLOGY
- Separated temperature management of ceiling and floor DUAL-TEMP® TECHNOLOGY
- Separated power management of ceiling and floor ECO-SMART BAKING® TECHNOLOGY
- Automatic cleaning program for carbonization
- Maximum temperature reached 270°C
- Continuous temperatures monitoring in cooking chamber by 2 thermocouples
- Vapour ducting using manual butterfly valve

### STANDARD EQUIPMENT

- Color multilanguage display TFT 5"
- 100 customized programs
- ECO-STAND BY® TECHNOLOGY for break
- POWER-BOOSTER® TECHNOLOGY for workload peaks
- HALF-LOAD® TECHNOLOGY for partial load
- Customized Hotkey with recurring control
- Self-diagnosis with error message display
- Independent double cooking Timer
- Weekly Timer with the possibility to program two lightings and two power off every day
- Independent security device of maximum temperature
- USB slot for data reading/input DATA-FEED® SYSTEM



**MORETTI FORNI S.P.A.**

www.morettiforni.com

info@morettiforni.com

Via A.Meucci, 4 - 61037 Mondolfo (PU) ITALIA  
Tel. +39.0721.96161 - Fax +39.0721.9616299



## S120E

### 2 baking chambers height 30cm

(assembled with support height 800mm)

TOP VIEW

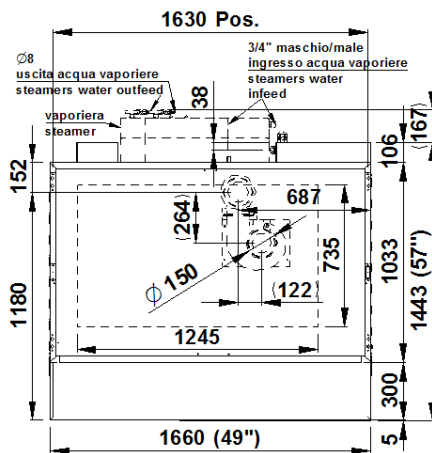

REAR VIEW

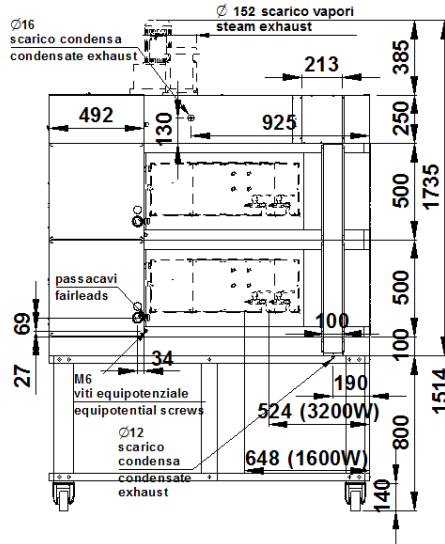

RIGHT SIDE VIEW

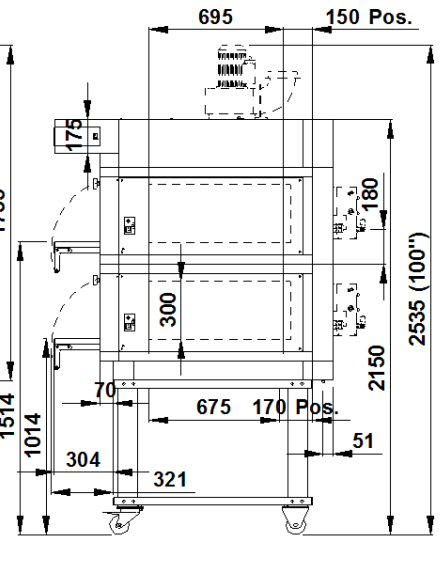

**Note:** The dimensions indicated in the views are in millimeters.

#### SPECIFICATIONS

The appliance comprises two independent cooking elements and an optional leavening compartment or support. The oven cooking surface is in buckle plate that provides perfectly even heat distribution over the whole surface, making this oven particular suitable to cook bakery. Temperature adjustment is electronic, with independent control of the ceiling and floor heating elements. The oven door is hinged at the bottom, with a tempered glass window to check the state of the product while it is cooking. The support comprises a painted metal structure, whereas the leavening compartment has a stainless steel structure and is fitted with a heating thermostat. The leavening compartment can reach a maximum temperature of 65°C, whereas the maximum temperature of the baking chamber is 270°C

All the data provided below refer to the configuration with 2 baking chambers

#### DIMENSIONS

External height	1350mm
External depth	1443mm
External width	1660mm
Weight	477kg
Baking surface	1,8m <sup>2</sup>

#### SHIPPING INFORMATION

Packed in wooden crate	
Height	1500mm
Depth	1643mm
Width	1870mm
Weight	(477+60)kg

#### FEEDING AND POWER

<i>Standard feeding</i>	
A.C. V400 3N	
<i>Feeding on request</i>	
A.C. V230 3	
Frequency	50/60Hz
Max power	24kW
Average power cons	7kWh
Connecting cable for each chamber	
type	H07RN-F
5x4mm <sup>2</sup> (V400 3N)	
4x6mm <sup>2</sup> (V230 3)	
Power supply (optional prover)	
A.C. V230 1N 50/60 Hz	
Max power	1,5kW
Average power cons	0,8kWh
Conn. Cable type	H07RN-F
3x1,5mm <sup>2</sup>	

#### TOTAL BAKING CAPACITY

When combined with leavening compartment or support:	
Tray (600x400)mm	6
Max height	2400mm
Max weight	(573+70)kg

\* This value is subject to variation according to the way in which the equipment is used

- NOTE: MORETTI FORNI S.P.A. reserves the right to modify the characteristics of the products illustrated in this publication without prior notice