



Austune Group
Austune Commercial Pty Ltd
Austune Australia Pty Ltd
3/35 Davis Road Wetherill Park 2164
Tel 1800 FRIDGE (37 43 43)
email info@austunecommercial.com

Austune C Series Undercounter Dual Temp Chiller Freezer

CURF225-4



FEATURES/ BENEFITS

Austune 1800 FRIDGE

C Series

Economical C Series From Austune 1800 FRIDGE

Digital Temperature Control System

Provides precise and constant temperature. This level of precision Allows food products to remain fresh over an extended period of time

High Tech Monitor

The monitor digitally displays present cabinet temperature. You can easily change the temperature by using the Thermostat

Hot Gas Condensate System

Prevents overflow of condensate water

Efficient Refrigeration System

R-134A utilized for chiller and R-404A for freezers. These include efficient evaporators and condensers for faster Cooling and greater efficiency

Adjustable Heavy Duty PE (Polyethylene) Coated Wire Shelves

Stainless Exterior and Interior

Stainless steel exterior (galvanized back and underside of base) Guarantees the utmost in cleanliness.

Model	Doors	Capacity	Shelves	Amps	Weight	W X D XH (mm)
CURF225-4	4	585 Litres	4	5.5	158 kg	2250x700x800



Note : Not To Scale

Design and Specification subject to change Without Notice

www.austunecommercial.com



Tel 1800 FRIDGE (37 43 43)

email info@austunecommercial.com

Austune C Series Undercounter Dual Temp Chiller Freezer

CURF225-4

Spec Sheet	CURF225-4
Classification	Refrigerator / Freezer
Orientation	Left hand side Compressor
Cooling Type	Ventilated,
Compressor (HP)	1/2
Temp range	-2c~+8c,/ -10 c ~ - 20 c
Refrigerant	R134a
Shelves	4
Display	LED Digital Display
Doors	4 Stainless Block with Locks
Controller	Dual Touch Digital
Internal Light	Yes
Castors	Lockable Multi Directional
Volume	Freezer 285 litre, Chiller 300 litre
Dimensions	W2250x D700x H800mm
Weight	158 KG
	Amps 5.5 Input Power 680W 220V/50Hz

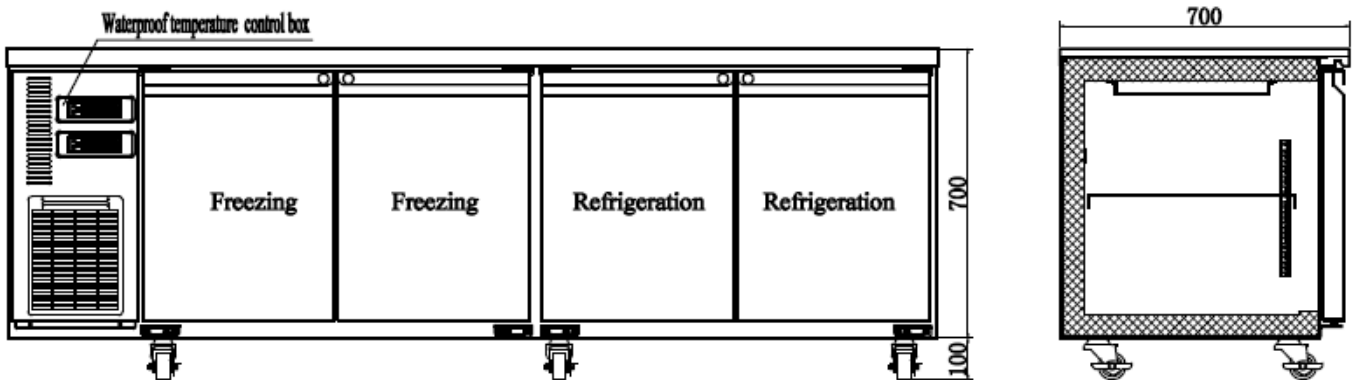

- *Easy clean removable front grill*
- *Stainless Work Top Included*
- *CFC Free Insulation*
- *Nationwide Service and logistics*

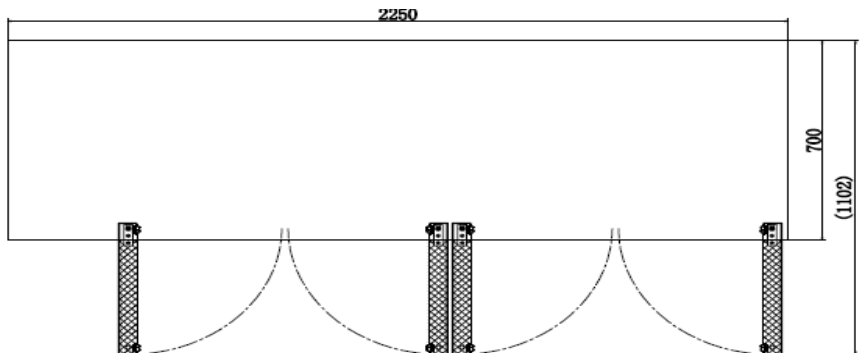

WARRANTY 2 YEARS
PARTS & LABOUR

Note : Not To Scale

Design and Specification subject to change Without Notice

www.austunecommercial.com