

The Australian owned and designed* Trueheat RC Series of Gas Cooking Equipment has been developed for the restaurant and cafe market with a high quality finish, designed to fulfill the busy demands within a commercial kitchen.

Powerful 24MJ/hr open burners with individual standing pilots included. 100% Flame failure controls included as standard. Matt finish Euro look cast iron trivets radiate heat and design makes it easy to move pots around the surface.

16mm thick steel griddle plate with 16.5MJ/hr burner per 300mm section.

Note: Griddle is convertible to left hand side. Additional charges apply.

DIMENSIONS & WEIGHT

External Dimension: 900W x 803D x 455H mm

Net Weight: 109kg

Working height : 910mm (with stand)

Combustible wall clearance: Side: 150mm, Rear: 150mm

TECHNICAL DATA

Gas Type: Natural or Propane

Total Output(MJ/hr):	Natural Gas	Propane Gas
	81	81

Burner Ratings (MJ/hr):	Natural Gas	Propane Gas	Ignition Type
Open Burner (MJ/hr):	24	24	Manual
Griddle per 300mm:	16.5	16.5	Piezo

Gas Connection: ¾" Female

AGA approval number: AGA 6652 G

SHIPPING DATA

Shipping Weight: 133kg

Shipping Dimensions: 980W x 900D x 600H mm

OPTIONAL ACCESSORIES

Part Number:	Description:
RCSTD9	900mm Stand complete with shelf
B05002	Adjustable leg for RCT countertop mounting
MS-CSTRB	Castor with brake to suit both 600mm and 900mm
MS-CSTR	Castor without brake to suit both 600mm and 900mm
432018-900HK	900mm ¾ flexible gas hose with quick connect fittings and restraint
432018-1200HK	1200mm ¾ flexible gas hose with quick connect fittings and restraint

SPECIFICATIONS ARE SUBJECT TO CHANGE WITHOUT NOTICE.

Note: Stands fitted with castors will need to be cut down by 120-150mm.



Stand sold separately

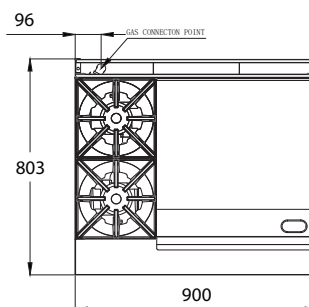
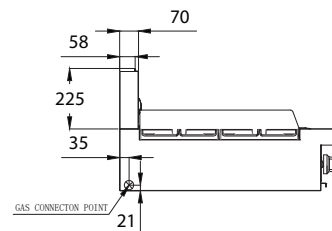
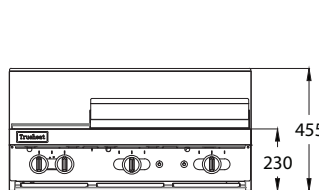

*manufactured in China