

Installation Requirements

Slayer Steam 2-group

Counter

- Width: 35 inches / 89 centimeters
- Length: 28 inches / 71 centimeters
- Height: 16.75 inches / 42.5 centimeters
- Weight: 220 lbs / 100 kg (tanks filled)

Measurements do not include overhanging components:
portafilters, brew actuators, cup rails

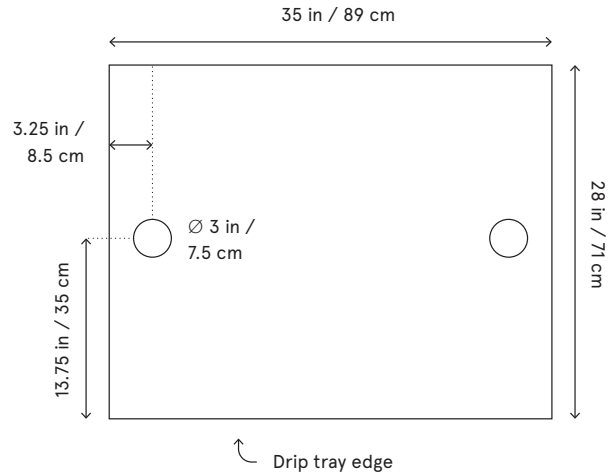

Water

- 3/8-inch BSP dedicated cold water line with shutoff valve (in North America, 3/8-inch compression fitting is included)
- Incoming water pressure: 3 Bar min, 5 Bar max
- Water hardness cannot exceed 50ppm, otherwise a water softener is needed

Power

- Single-phase: 200-260 volts AC, 50/60 hertz, 26 amps, 5,700 watts
- Three-phase: 380-400 volts AC, 50/60 hertz, 17 amps, 5,700 watts
- Receptacle: Nema 6-50

Drain

- Open gravity drain located within 4 feet / 1.2 meters of the machine
- Two (2) drain hoses: 7/8-inch outside diameter, 5/8-inch inside diameter (2.2-centimeter outside diameter, 1.6-centimeter inside diameter)
- Ensure drain lines are always sloping downwards

