



## Panini Grill

*“Anvil’s panini sandwich press is designed to create a ribbed effect on sandwiches. It can also be used as a griddle for steak, tomatoes, bacon etc. This unit is designed to operate consistently between 15 and 24hrs a day.”*

## Model: PGT0001

### APPLICATION

- Use for panini sandwiches as well as English or Italian sandwich cuisine
- They are perfect for delis, bars, cafes and many other food service operators
- Allows operator to create a ribbed effect on the exposed surface of the food with the convenience of a flat frying surface

### CONSTRUCTION

- An adjustable top plate for a variety of food thicknesses
- Innovative plate design gives improved performance
- Drip cup to catch excess grease
- Heat resistant handle
- Pilot light indicates when plates are energised

### HEATING

- Thermostat heat controlled up to 300°C
- Unique plate design allows for maximum heat transfer and even heat distribution



 ANVIL

# AXIS



ALL ANVIL EQUIPMENT COMES WITH A ONE YEAR WARRANTY ON COMPONENTS AND DEFECTIVE WORKMANSHIP.  
[www.anvilworld.com](http://www.anvilworld.com)

S  
A  
X

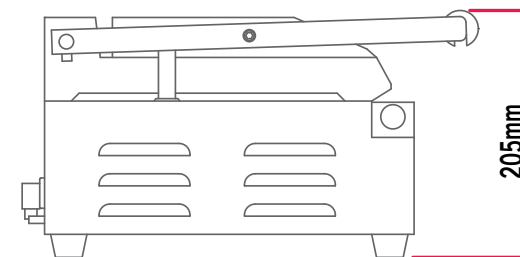
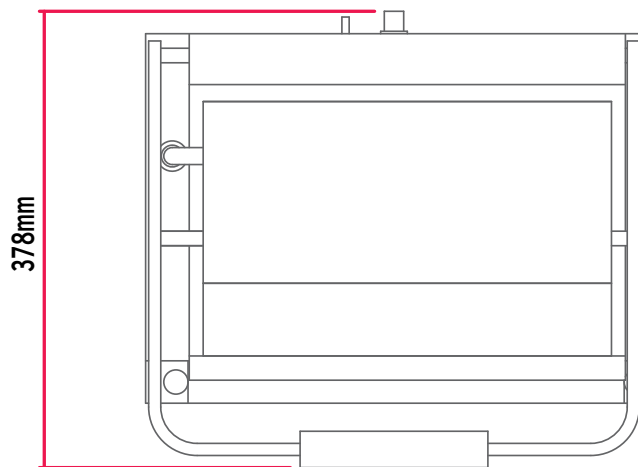
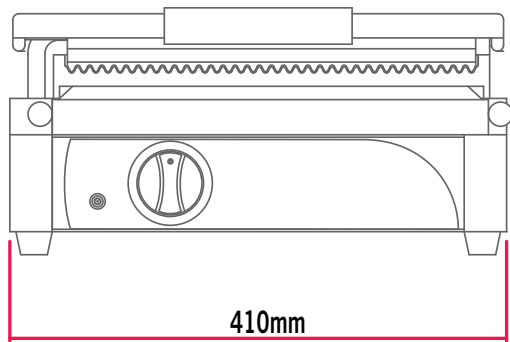

## DESCRIPTION

MODEL  
POWER RATING (230V/50Hz)  
DIMENSIONS (mm) (W x D x H)  
BOX DIMNS (mm) (W x D x H)  
PACKED WEIGHT (kg)  
COMPLIES WITH SPEC

- Unit available in 120V/60Hz configuration

## PANINI GRILL

PGT0001  
2.2kW  
410 x 378 x 205  
460 x 420 x 260  
14  
SABS IEC 60335

# Model: PGT0001

NOTE: When viewing the appliance from the front in its usual operating position, the width (W) of the product is the total distance from left to right; the depth (D) of the product is the total distance from the front to the back; the height (H) is the total distance from the bottom of the product to the top.

 ANVIL

# AXIS

Note: Output performance figures quoted are dependant on various factors

Anvil reserves the right, without notice, to make changes and revisions to product specifications, materials and design, which in our opinion, will provide better performance, durability and efficiency.