

BROMIC[®] **REFRIGERATION**

Curved and Square Glass Delicatessen
Displays
Commercial Refrigeration Range

USER MANUAL

USER AND MANTINANCE MANUAL SERVE OVER COUNTER

1. WARNING
 2. GUARANTEE
 3. INSTALLATION AND ASSEMBLY
 4. TECHNICAL CHARACTERISTICS AND CONDITIONS OF USE
 5. START-UP
 6. RECOMMENDATIONS
 7. PRECAUTIONS
 8. MAINTENANCE
 9. OPERATIONAL TESTS
 10. DECOMMISSIONING
 11. ELECTRIC SHEME
 12. COLD SHEME
- ANNEX NORMATIVE

INICIAL NOTICE

Before turning the unit on we recommend you to read the instructions and follow the steps as explained

**ATTENTION: THE BROMIC DELICATESSEN DISPLAY REFRIGERATION RANGE IS
NOT APPROVED FOR DOMESTIC USE
If you have purchased a unit for domestic application, please contact your supplier or
Bromic refrigeration immediately**

We would like thank you for your confidence in us for having purchased this refrigerated unit. This manual has been prepared in order to safeguard the security of the user and ensure the correct use and maintenance of the refrigerated units. Please read it carefully before starting up your unit. The refrigeration unit strictly complies with all applicable European directives and standards.

■ **1. WARNING**

Before carrying out any operation, whether as installation technician or as the user of the unit, you should be aware of the points explained in this manual.

This manual should be kept in a safe place and should be available for reference. In case of loss, request a duplicated indicating model, serial number and date of purchase.

The manufacturer considers that both the installation technician and the user of the unit must have the most basic training in order to understand the contents of this manual, as well as an awareness of standard hygiene and safety principal.

If required, this unit must be repaired exclusively by qualified technical personnel.

ATTENTION Access to all electrical part of the unit, either installation or maintenance issues, is authorized qualified personnel only.

The user will be responsible for the following items:

- Suitability of the premises to the requirements of the purchased unit.
- Electricity supply in accordance with the current standards and sufficient for the consumption and safety of the unit.
- Material necessary to clean the unit.
- Water point or drainage outlet as necessary for the installation of the refrigerated unit.

The manufacturer disclaims all liability in the following situations:

- Inappropriate use of the purchased unit.
- Possible damage to person or property caused by improper installation.
- Installation not carried out following the procedures described in this manual.
- Defects in the electricity supply.
- Unauthorised modifications or interventions.
- Use of spares not specific to the model.
- Total or partial non-compliance with the instructions.
- Incidents caused by transportations company or movement of the unit to its place of installation.

For any questions you need to contact your dealer.

■ **2. GUARANTEE**

The guarantee for the unit and the parts that comprise it are guaranteed for one year starting from the date of sale and consists of the replacement (carriage unpaid) of the defective component or component, provided that it is not as a result of the misuse of the same.

The guarantee doesn't include labor resulting from the replacement of components.

The guarantee will not cover breakdown or breakage of components, even when the same occurs within the established period, arising from subjecting the unit to working conditions other than those established in this manual and the details of each model contained in the catalogue (failure in the power supply, high ambient temperatures, windows, lighting, etc...).

3. INSTALLATION AND ASSEMBLY

The unit must not be moved from its standard vertical position, however as necessary, some appliances may be placed face down only as indicated on the packaging.

You are advised to unpack the unit standing on a solid, flat and stable surface. In order to transfer it to the installation location, a trolley or fork-lift may be of help. It should not be dragged along the ground and always watch out to ensure it is not off-balance.

Next, remove the packaging to leave the unit completely free of all coverings and packing material, whilst avoiding knocks to the appliance, scratching it or unscrewing the feet.

Once placed in its final location, it should be pulled away from the wall so that there is a space of 10 cm at the back and a minimum of 10 cm to the sides.

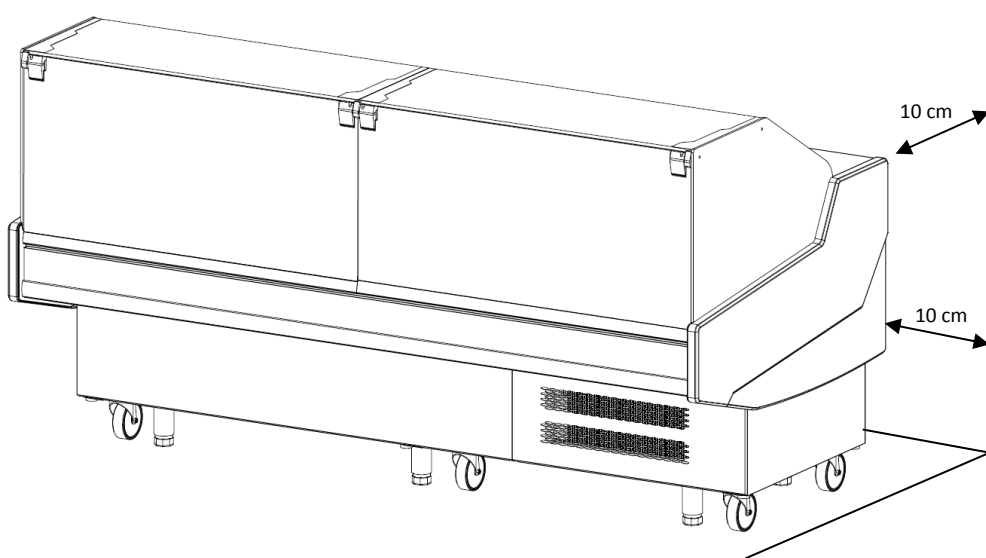

The unit is equipped with drain cleaning, we recommend connecting it directly to the appropriate device or a receptacle should be positioned in order to collect the water.

FIRST CLEANING

First of all, remove the protective film from stainless steel using any non-sharp object. Remove also possible glue remains using alcohol.

Avoid completely the use of tools or elements that may be able to scratch or damage the unit. Once cleaned and dry, assemble accessories on correspondent places.



We recommend a regular cleaning of the stainless steel with some neutral soap, warm water and sponge, drying it afterwards. **DO NOT USE ANY DETERGENTS, ANY PRODUCT CONTAINING CHLORIDE, SULPHIDE OR ANY OTHER ABRASIVE AGENTS. ALWAYS KEEP ELECTRIC PARTS AWAY FROM WATER.**

ATTENTION

Please do not use iron, nickel sponges to clean **STAINLESS STEEL** or leave them lying on the surface as the iron deposits can stick and cause the formation of rust contamination, thus jeopardising the hygiene of the surface.

■ 4. TECHNICAL CHARACTERISTICS AND CONDITIONS OF USE

The technical data of the unit, model and serial number are identified by means of the information displayed on the registration or on the data sheet that appears on all the products.



Serial n.



MODEL	DD0XXXXX	PRODUCTION YEAR	XXXX
EQUIPMENT	H	CONDENSATION	V
Refrigeration Capacity W	XXX	LAMP POWER W	XX
Refrigerant	R-404 A	Temp range (°C)	-1 - 5
Voltage	230	Mass (gr.)	XXX
Absorption (A max)	X.X	HZ	50
Heating System Power W	XXX	Output Power W	XXX
Climate Class	3	Foaming Agent	
Protection Class	1	C4HF5F5	

Apart from the identifying data of the unit, information relating to the gas refrigerant and electrical voltage to which the unit must be connected is also displayed.

The serve over counter are prepared to conserve fresh products or pre-cooked, foods, as well as the refrigeration of drinks. The range of temperatures of the unit must be selected taking into account the following points:

- Type of product for refrigeration or conservation
- Ambient temperature.
- Frequency with which the doors are opened.

According to UNE -EN ISO 23953-2 : 2013, the serve over counter are classified as:

CLASS	High temperature	Low temperature	Low temperature
	°C		
L1	-15	-	-18
L2	-12	-	-18
L3	-12	-	-15
M1	+5	-1	-
M2	+7	-1	-
H1	+10	+1	-
H2	+10	-1	-
S	Special classification		

• **COMPOSITION OF THERMAL INSULATION**

The thermal insulation is made from expanded polyurethane 40 kg/m³, with expansive agent C4H5F5.

■ 5. START-UP

• **FIRST CLEANNING**

Clean the unit before connecting to the electricity supply.

• **INSPECTION**

- Check that the voltage and power line frequency coincide with those indicated on the specification plate of the appliance.

- The unit should not be used in threatening atmospheric or fire risk conditions.
- Check that there are no defects on the unit resulting from its transportation. The manufacturer will not be liable for damage suffered during transportation or arising from incorrect storage.
- Check the operation of the moving components of the unit.
- Check the safety of the control board, electrical cables and connections.
- Check that all the interior and additional accessories are present.

• **GENERAL CONNECTIONS**

- Be sure the power cable is not damaged.
- If the power cable is damaged it must be replaced by another type H05-VV-F or H05-VVH2-F. This repair must be performed by qualified personnel.
- It is essential that the electrical installation to which the unit is going to be connected has an **EARTH LEAD**, as well as the necessary thermal and differential magnetic protection.
- The power supply must have the suitable section for the consumption of the appliance.
- If various units are installed in a row, each one must be connected independently to the power supply, avoiding the use of extension leads or multiple plugs.
- The manufacture disclaims all liability in the event that any of the above points are not followed.

• **OPERATING ELEMENTS AND INDICATORS**

CAREL:

- One the inside of the unit is clean, connect the power supply and place the switch in the **I/ON** position. The switch should be lit up. The thermostat display shows the air temperature inside the unit.
- Three minutes after turning on the switch, the LED showing the compressor is working will light up permanently.
- The initial temperature that is shown on the thermostat display will be the ambient temperature. As the machine works, the temperature will reduce until it reaches its operating temperature.

TURN ON/ OFF

Press  until appear **ON** to turn on the unit.

To turn off the computer press the button for 5 sec until appear **OFF** and the condensing unit will stop working.

Check set point

Press  "set" 1 sec and the set point or set point will appear. Release key.

Up the set point

Press  "up" .Release key.

Lower set point

Pulsar  "down" . Release key.

To set the new value, press



and appears the value of the temperature of the room probe.

ELIWELL:



NOTE
When switched on, the device performs a Lamp Test; the display and LEDs will flash for several seconds to check that they all function correctly.

	Reduced SET / Economy LED Permanently on: Energy Saving active Flashing: Reduced SET active Quick flashing: access to level2 parameters Off: otherwise		Fans LED Permanently on: fans active Off: otherwise
	Compressor LED Permanently on: compressor active Flashing: a delay, a protection or a locked start-up Off: otherwise		Defrost LED Permanently on: defrost active Flashing: manual or D.I. activation Off: otherwise
	Alarm LED Permanently on: alarm active Flashing: alarm acknowledged Off: otherwise	AUX	Aux LED Permanently on: Aux output active Flashing: Deep Cooling cycle active Off: Aux output not active
°C	°C LED Permanently on: °C setting (dro = 0) Off: otherwise	°F	°F LED Permanently on: °F setting (dro = 1) Off: otherwise

	UP Press and release • Scroll menu items • Increases values Press for at least 5 sec • Activates the Manual Defrost function		DOWN Press and release • Scroll menu items • Decrease values Press for at least 5 sec • Function can be configured by the user (see parameter H32)		STAND-BY (ESC) Press and release • Returns to the previous menu level • Confirms parameter value Press for at least 5 sec • Activates the Standby function (OFF) (when outside the menus)	set	SET (ENTER) Press and release • Displays alarms (if active) • Opens Machine Status menu Press for at least 5 sec • Opens Programming menu • Confirm commands
--	--	--	--	--	---	------------	---

Although it is possible to select or reprogram the temperature by manipulating the thermostat, it is not advisable, as this may cause the improper operation of the unit, changing the purpose for which it was programmed, and for this reason such manipulation should never be done.

The user of this unit will be responsible for the damage caused to it through non-compliance with the observation described in the above point. The units designed for the storage of frozen foods are suitable for the conservation of frozen foods and not for freezing the product.

The environmental operational limits established for the units are shown by climatic category:

Climate category	Dry bulb temperature°C	Relative Humidity %	Dew point °C	Mass of water vapor in dry air g/kg
0	20	50	9.3	7.3
1	16	80	12.6	9.1
2	22	65	15.2	10.8
3	25	60	16.7	12.0
4	30	55	20.0	14.8
6	27	70	21.1	15.8
7	35	75	30.0	27.3
8	23.9	55	14.3	10.2

■ **6. RECOMMENDATIONS**

- In order to obtain better performance, avoid the introduction of hot foods as well as drinks that are not in sealed packages.

- Protect foods and their odours by using some hermetic closing system, placing them in the unit in such a way that allows for a good circulation of air, respecting the maximum load indicated on the inside of the unit.
- Avoid as far as possible the frequent opening of doors and above all, do not leave the doors open.
- Avoid placing sheets of cardboard or paper on the perforated shelves as these will obstruct the circulation of air.
- The maximum weight for glass shelf will be 8 kg/m, distributed evenly and 60kg/m for shelf exposure.

When the unit has to be turned off for a long period of time, the following steps are recommended.

- Remove the products from the inside of the unit.
- Disconnect the main switch and unplug the unit.
- Clean the inside and outside of the unit.
- Partially open the door so that air can circulate and in this way avoid foul odours.

■ 7. PRECAUTIONS

- The stability of the unit is guaranteed, even when the doors are open, however leaning on the doors is completely prohibited.
- Do not modify the specifications plate or instructions issued by the manufacturer.
- Do not touch the unit with wet or damp hands and feet.
- Do not touch the unit when barefoot.
- Do not pull the cable to unplug the unit.
- Avoid the use of adapters, extension leads or multiple plugs.
- Before carrying out any cleaning or maintenance operation, unplug the unit from the electricity supply, first turning off the main switch and then unplugging the unit.
- The unit **must not** be used by children, persons whose mental, sensory or physical capacities are impaired. Persons who lack experience or knowledge must be supervised or given instructions for use.
- In those units equipped with metallic drawers, it is not advisable to load them with more than 30kg weight per drawer or 25kg in plastic boxes, ensuring in all cases that the load is uniformly distributed. For this reason sitting or leaning on the drawers is not allowed.
- Do not remove the protection from the movable components without having previously disconnected the power supply.
- Take necessary precautions before manipulating the condenser unit area, due to the existence of high temperatures of some of the components and the resultant risk of burns.

■ 8. MAINTENANCE



Before carrying out any cleaning operation, disconnect the unit from the power supply and place the main switch in the **OFF** position.

The units are equipped with a drainage outlet to make cleaning easier, as well as allowing for the eventual seepage of liquids from the foods. During cleaning, the drainage outlet cover has to be removed and cleaned in order to avoid being blocked by solid elements being pulled into it.

The good operation and performance of the unit will largely depend on its correct maintenance, carried out periodically.

The manufacturer is exempt from all liability arising from non-compliance with the procedures contained in this manual.

• GAS CONDENSER

The incorrect maintenance and lack of cleaning of the gas condenser of the refrigerated unit can considerably reduce the performance of the unit as well as shortening the life of the compressor motor. The cleaner the unit, especially the condenser fins, **the greater the energy saving.**

In any event, it is recommended that this task is **carried out by a service technician.** In the case of any doubt, please contact your distributor. We recommend that this operation is carried out at least once every three months and at the start of every summer.



The cleaning of the gas condenser must be carried out with the unit unplugged and removing the protectors (grills) or taking out the condenser unit (depending on the model)

In order to remove the dirt deposited between the condenser fins, any of the following procedures are recommended:

- Use a toothbrush or soft-bristle brush.
- Blow the dirt using a suitable appliance.
- Use air pressure to remove the dirt.

- **EVAPORATORS**

Only for specialist personnel

The only maintenance the evaporators require is proper cleaning. This has to be done with the machine stopped and once the ice that may be present on the fins has melted or once defrosting has been done by operating the controls. This process may be accelerated by using warm water, **NEVER** using hard or sharp objects.

In order to clean the coil or the casing, **DO NOT** use chemical de-greasers with acid compounds or bleach, chlorine, ammonia or salts as all these products aggressively attack copper and aluminium. Only water with well-diluted neutral detergents should be used or products especially designed for cleaning the evaporators of refrigerated units. The cleaner the unit, **the greater the energy saving.**

- **AUTOMATIC EVAPORATION TRAY**

Only for specialist personnel

The majority of the units are equipped with an automatic evaporation tray for the situations where an external outlet is not available to collect the defrosted water from the evaporators. If this tray is not included, the drainage tubes have to be connected directly to the appropriate device or a receptacle should be positioned in order to collect the water.

The defrost water can also cause breakdowns as the piping that brings the heat necessary for the water to evaporate can be punctured or the electrical resistance can deteriorate.

The duration and number of defrosts the refrigerating equipment is regulated at the factory. The user should not change this regulation.

Attention should be given to this tray and regular cleaning is recommended.

- **DOOR SEALS**

The rubber door seals are designed to ensure the closure of the doors to the cold chambers and to guarantee the sealing of the doors against external elements.

A magnetic strip is housed on the inside of the rubber seal, which adheres it to the frame of the unit. Over time granular particles can become stuck in the seal due to the effect of the magnet and these can rust and cause stains.

It is recommended that these door seals are kept free from foreign bodies that can cause rust, as well as fatty deposits which, over a long period of time, can affect the rubber of the door seal.

Clean them with water, using neutral soap and a damp cloth. **DO NOT USE DETERGENTS OR ABRASIVE PRODUCTS.**

■ **9. OPERATIONAL TEST**

- **CHECKS IN THE EVENT OF OPERATIONAL FAILURE**

In some situations, operational failure can arise due to simple causes that users themselves can solve, which is why prior to requesting the intervention of a specialised technician, we recommend that you carry out the following checks.

The appliance does not work

- Check that it is correctly plugged in.
- Check that electricity reaches the power outlet.
- Check that general switch is in the **I/ON** position.

The internal temperature is too high

- Check that there is no heat source nearby.
- Check that the grill is not obstructed.
- Check the Set-point.
- Check that the product loaded is perfectly distributed, without blocking the interior air ventilation exits and that the time elapsed since loading has been sufficient to chill the products.
- Check if the evaporator has ice.
- Check that the condenser is not obstructed.
- Check that the appliance is functioning normally.

In the event of strange or excessive noises

- Check the levelling of the unit as this may cause vibrations.
- Check that there is no object rubbing against any movable element of the refrigerated unit.

- **NOISE TESTING**

- The noise tests were performed in a room without any noise absorption elements and without any large item placed near to the refrigerated unit.

- The noise levels registered in the acoustic test have been carried out in accordance with the ISO 230 to 235 standards.

Leq (continuous level) is less than 70 dB. (A)

Lp (acoustic pressure level) is less than 130 dB. (C)

NOTE. (A) (C) Frequency weights.

- **10. DECOMMISSIONING**



Decommissioning

The refrigerator cabinet containing polyurethane foam , oil, plastic parts , metal parts and electrical and electronic components. When the life of the furniture has come to an end and is necessary to remove the cabinet for destruction or partial recovery , the user is responsible for delivering the product to the collection specified by the local authority for recovery and recycling WEEE professionals, always respecting the laws in force . The manufacturer is responsible for recovery, treatment and disposal at end of product life , in direct way or through a collective system make possible . If the rules are violated specific sanctions , established autonomously , according to the laws of each state belonging to the EC and conformally linked to all who are subject to those rules apply



Dismantling furniture

In accordance with the rules on waste disposal in force in each country and full respect for the natural environment , we recommend subdividing the different parts of the furniture according to the material , separately or eliminate back. This product contains HFC , ie , fluorinated gases with high value of greenhouse gas (GWP). So: The component parts of the cooling circuit can not be cut or separated until the refrigerant gas has been extracted for recovery in a specialized center.



Declaration of conformity RoHS

He declares under its own responsibility that the refrigerated cabinet to which this manual refers , meets the requirements of Directive 2002/95 / EC / (RoHS) In all homogeneous materials used for manufacturing , the possible existence of lead, mercury , hexavalent chromium , polybrominated biphenyls (PBB) and diphenyl ether (PBDE) does not reach 0.01% by weight . This statement is based on statements of our suppliers of raw materials and components .

■ 11. ELECTRIC SCHEME.

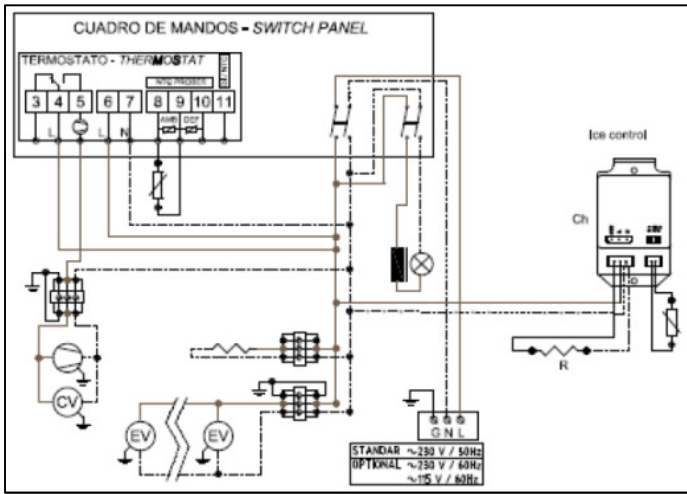

Models **DD0150SG-DD0200SG**
Models **DD0150CG-DD0200CG**

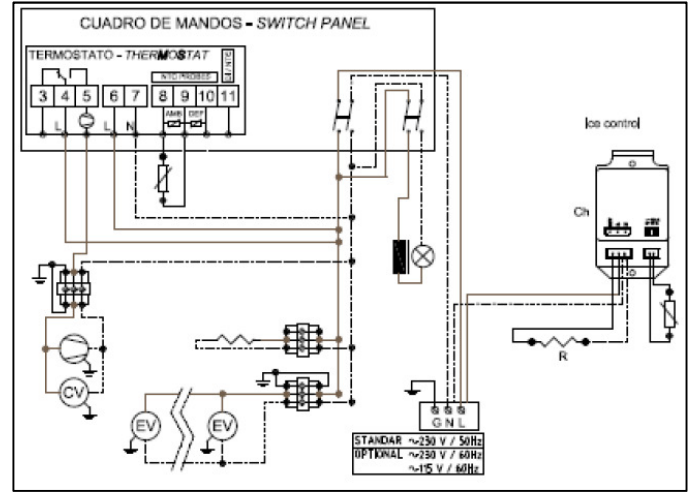

Models **DD0250SG-DD0300SG**
Models **DD0250CG-DD0300CG**

■ 12. COLD SCHEME.

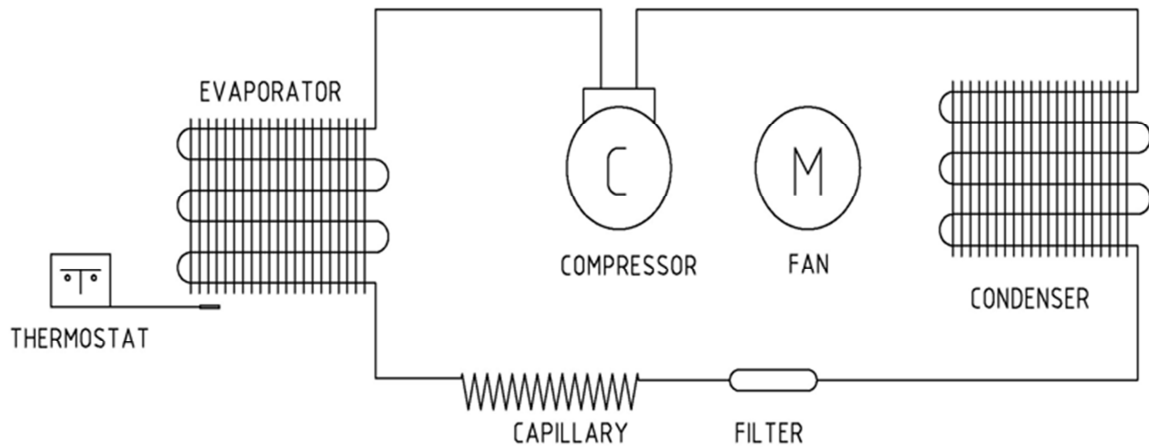

BROMIC[®]
REFRIGERATION