

**Specification, Installation  
and Operation Manual**

**Snack Master Series 10, 15 & 20**

Models:  
W.CVS.S.10, W.CVS.S.15, W.CVS.S.20

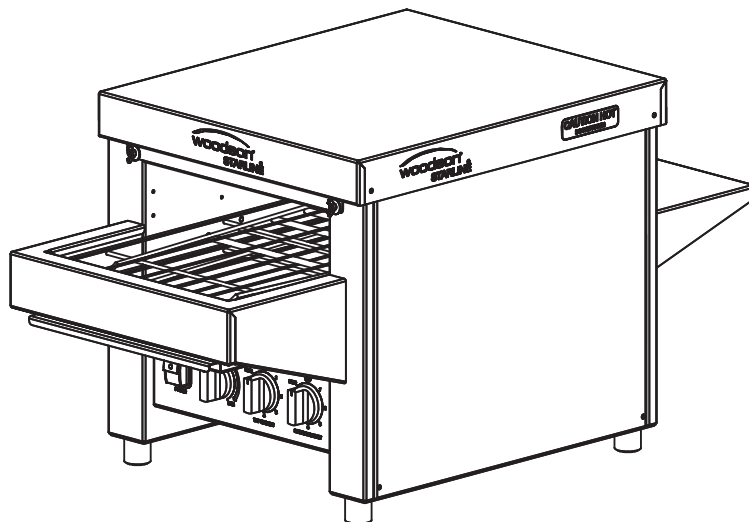

A guide on the use, care and maintenance  
of your quality Woodson Starline product

## Introduction

Your New Woodson Starline Product.....	3
Optional.....	3
Product Overview.....	3

## Specification

Attention.....	4
General Precautions.....	4
<i>Service</i>	
<i>Hot Surfaces</i>	
General Drawing.....	6
Technical Specifications.....	7
Electrical Connection.....	7
<i>Information</i>	

## Installation

Setting Up.....	8
<i>Handling</i>	
<i>Unpacking</i>	
<i>Positioning</i>	

## Operation

General Recommendations.....	9
Operating Instructions.....	10
<i>First Time Operation</i>	
<i>Element Settings</i>	
Cleaning.....	11-12
<i>General Information</i>	
<i>Corrosion Protection</i>	
<i>Surface Finish</i>	
<i>Cleaning Schedule</i>	
<i>Materials Required</i>	
<i>Cleaning Procedure - Conveyor and Crumb Tray</i>	
<i>Cleaning Procedure - External Surfaces</i>	
Troubleshooting.....	13

**Warranty**

Commercial Warranty.....14  
Consumer Warranty.....14  
Warranty Clarification.....14  
Warranty Claim Procedure.....15  
Timing of Warranty Services.....15  
General Maintenance and Repairs.....15  
Warranty Request Form.....16

**Notes**

Notes .....17

**Contact**

Stoddart Service Department.....18

## Your New Woodson Starline Product:

Thank you for purchasing a Woodson Starline product.

By using, caring and maintaining your product according to these instructions, your Woodson Starline product should give you many years of reliable service.

Woodson Starline equipment has been designed to give maximum and efficient performance and while integrating a user friendly operating system for all staff and end users.

At Stoddart, we take pride in manufacturing the Woodson Starline product line and are committed to standing behind our customers and products 100%. Should you ever need assistance, please contact the Stoddart Service Department at **1300 307 289**.

## Optional:

Woodson Starline highly recommends the use of steel trays when required.

## Product Overview:

Configuration may vary according to model.

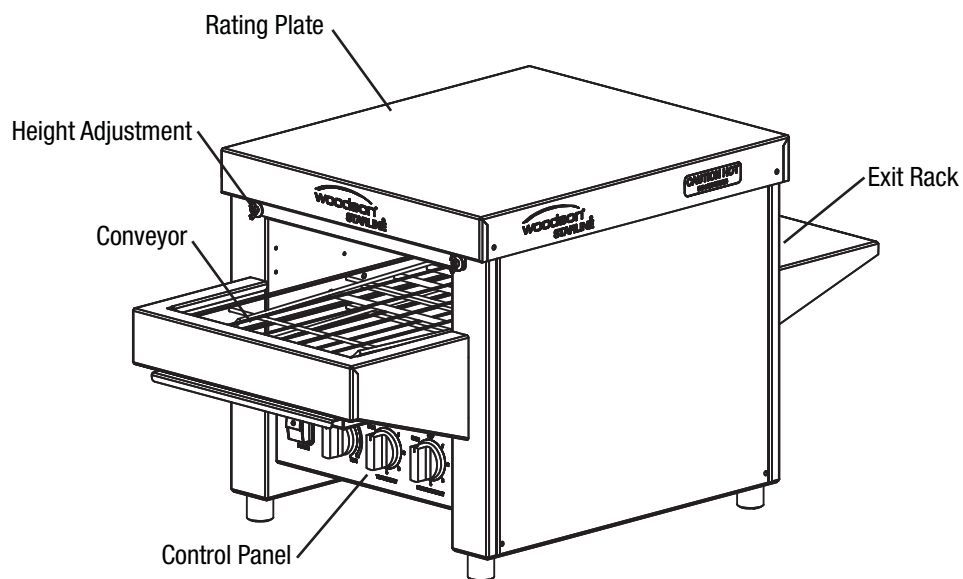

## Attention

Carefully read this instruction booklet, as it contains important advice for safe installation, operation and maintenance. Keep this booklet on hand in a safe place for future reference by other operators or service technicians.

### ***Disclaimer:***

The manufacturer and distributor cannot be held responsible or liable for any injuries or damages of any kind occurred to persons, appliances or others, due to abuse and misuse of this appliance in regards to installation, un-installation, operation, servicing or maintenance, or lack of conformity with the instructions indicated in this documentation.

All appliances made by the manufacturer are delivered assembled, where possible, and ready to install. Any installation, un-installation, servicing, maintenance and access or removal of any parts, panels or safety barriers that is not permitted, does not comply in accordance to this documentation, or not performed by a TRAINED AND AUTHORISED SPECIALIST will result in the IMMEDIATE LOSS OF THE WARRANTY.

The manufacturer cannot be held responsible or liable for any unauthorized modifications or repairs. All modifications or repairs must be approved by the manufacturer in writing before initiating. All modifications or repairs performed to this appliance must be performed at all times by a TRAINED AND AUTHORISED SPECIALIST.

## General Precautions

- This product is not designed for household or domestic use and should not be used for this purpose.
- Only use this appliance with voltage specified on the rating label.
- Do NOT remove any cover panels that may be on the appliance.
- This unit is NOT waterproof. Do NOT use jet sprays or hoses to the exterior of the appliance.

## Service

- Qualified personnel, specifically trained in the following instructions, can perform service of the appliance.
- Stoddart, one of our agents, or a similarly qualified person(s) should carry out any and all repairs, maintenance and services.

## Hot Surfaces

- This unit can get very hot. Ensure everyone is aware that the appliance is operating and take care to avoid contact with hot surfaces.

Page Intentionally Left Blank

General Drawing

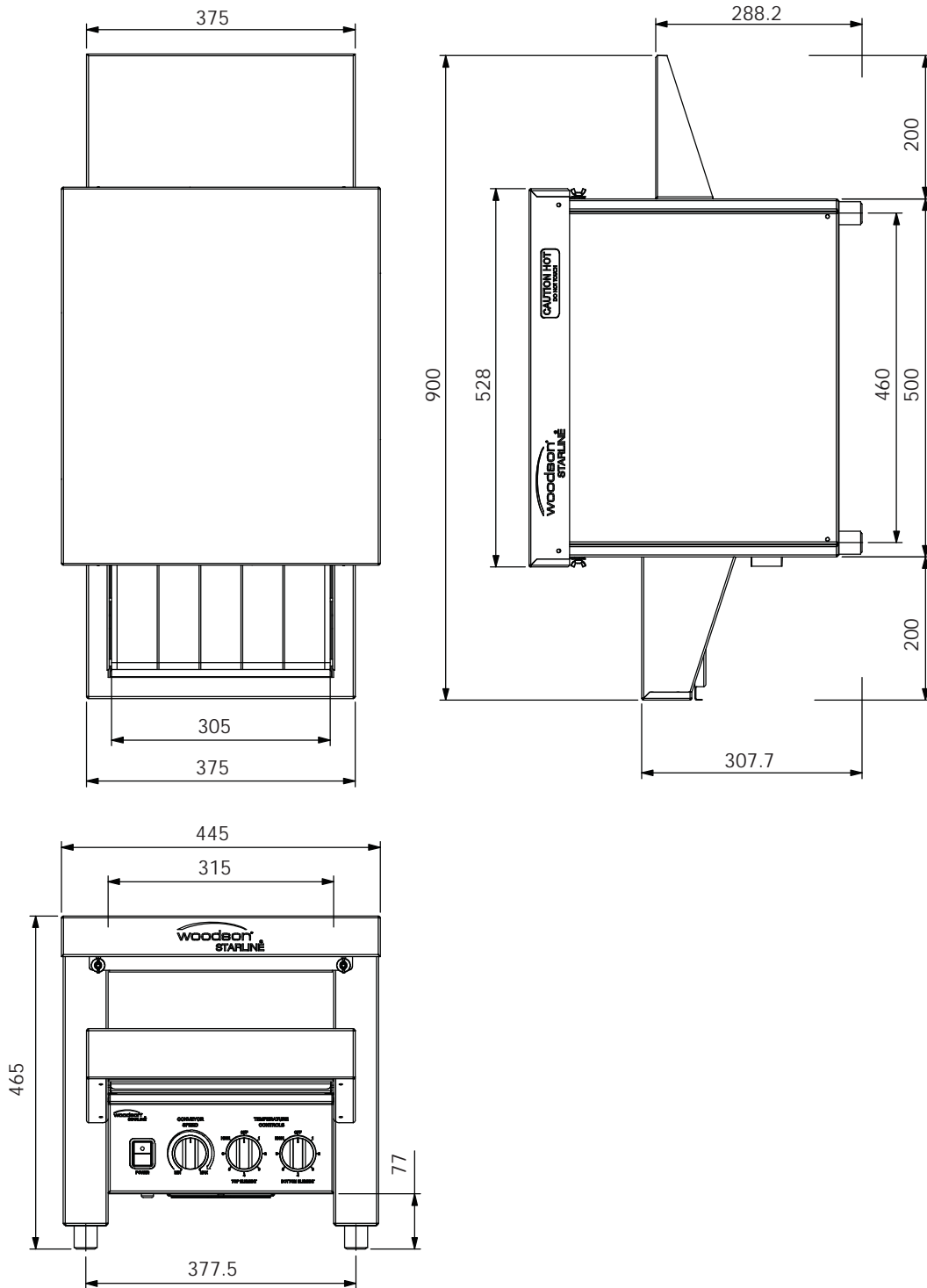

## Technical Specifications

Specifications	
Model	W.CVS.S.10 / W.CVS.S.15 / W.CVS.S.20
Height	465mm
Width	900mm
Depth	445mm
Power	2.4kW / 3.6kW / 4.8kW
AMPS	10A / 15A / 20A

Approx. Shipping Size	
Model	W.CVS.S.10 / W.CVS.S.15 / W.CVS.S.20
Height	565mm
Width	1000mm
Depth	545mm

## Electrical Connection



**WARNING!**  
This unit must be installed in accordance with AS/NZS 60335.1

### Information

- The electrical supply must comply with the rating plate data.
- Ensure that the machine is connected to a suitably rated and earthed power source.
- Regulations require that all units be installed to the appropriate Australian standards.
- Regulations require that authorised persons carry out all electrical work.
- The machine must be plugged directly into the power outlet. Extension leads or power boards are not to be used.
- The equipment should be earthed according to local electrical codes to prevent the possibility of electrical shock. It requires an earthed receptacle with separate electrical lines, protected by fuses or a circuit breaker of the proper rating.
- If the supply cord is damaged, it must be replaced by the manufacturer, its service agent or similarly qualified persons in order to avoid a hazard. Please contact Stoddart for parts and we will advise how to do this in order to avoid any electrical hazard.
- The power cable should be dry and or isolated from moisture or water.



**WARNING!**  
Some procedures in this manual require the power to the equipment to be turned off and isolated. Turn the power OFF at the power point and unplug the power supply lead by the plug body. If the power point is not readily accessible turn the equipment off at the isolation switch or the circuit breaker in the switchboard. Attach a yellow "CAUTION-DO NOT OPERATE" tag. This must be performed where relevant unless the procedures specify otherwise.  
**FAILURE TO DO SO MAY RESULT IN ELECTRIC SHOCK.**



## Setting Up

Improper installation, adjustments, alterations, service or maintenance can cause property damage, injury or death.

### Handling

- Use suitable means to move the appliance: eg. A lift truck or fork pallet trucks (the forks should reach more than halfway beneath the appliance)

### Unpacking

- Check the appliance for damage before and after unpacking. If unit is damaged, contact the distributor and manufacturer
- Should any item have physical damage, report the details to the freight company and to the agent responsible for the dispatch within seven (7) days of receipt. No claims will be accepted or processed after this period
- The appliance is supplied fully assembled.
- Remove all protective plastic film, tapes, ties and packers before installing and operating.
- Clean off any remaining residue from the interior exterior of the appliance using a clean cloth dampened with warm soapy water.

### Positioning

- Choose an area that is well ventilated and that provides access for future maintenance.
- Place the appliance on a level stable work surface capable of supporting its weight.
- Do not position the unit in a wet area, an area with a lot of heat and steam or near inflammable substances.
- Allow an air gap between the appliance and other objects or surfaces. We recommend a minimum gap of 100mm for normal operational use (if the appliance is near any heat sensitive material we suggest you allow additional space)
- Please consult national and local standards to ensure that your appliance is positioned in accordance with any existing requirement
- Do not stack the units on top of each other.

### Electrical Supply

- Unit should be plugged into an appropriately rated electrical supply in accordance with the instructions and technical specifications contained in this manual.

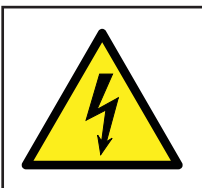

**Important!**  
**When hard wired, ensure that a qualified technician sets up and installs this unit.**

Due to continuous product research and development, the information contained herein is subject to change without notice.

## General Recommendations

When using any electrical appliance, safety precautions should always be observed.

Our appliances have been designed for high performance. Therefore, the appliance must be used exclusively for the purpose for which it has been designed.

Read these instructions carefully and retain for future reference.

- All units **MUST** be installed according to the procedures stated in the installation section of this manual.
- This product is not intended for use by persons (including children) with reduced physical, sensory or mental capabilities, or lack of experience and knowledge, unless they have been given supervision or instruction concerning the use of the product by a person responsible for their safety. Children should be supervised to ensure that they do not play with the product.
- In the case of new personnel, training is to be provided before operating the equipment.
- Do **NOT** use this appliance for any other purpose than its intended use.
- Do **NOT** store explosive substances such as aerosol cans with a flammable propellant in or near this appliance.
- The surfaces of this unit are **HOT** when in operation. Signage should be displayed for personnel and customers.
- Keep fingers out of “pinch point” areas. Clearances between the openings, pans and panels are necessarily small.
- This unit is **NOT** waterproof. Do **NOT** use jet sprays or hoses to the exterior of the appliance.
- If the supply cord is damaged, it must be replaced by the manufacturer, its service agent or similarly qualified persons in order to avoid a hazard. Please contact Stoddart for parts and we will advise how to do this in order to avoid any electrical hazard.
- Avoid touching any moving parts.
- Do **NOT** use sharp objects to activate controls.
- If any fault is detected, refer to troubleshooting on **page 13**.
- Do **NOT** use in an explosive atmosphere.
- Avoid exposure to direct heat and/or humidity sources.
- The manufacturer declines any liability for damages to persons and/or things due and to an improper/wrong and/or unreasonable use of the machine.

Due to continuous product research and development, the information contained herein is subject to change without notice.

## Operating Instructions

### First Time Operation

1. Turn the unit on at the "Power Switch". (The fan will start running).
2. Prepare food item.
3. Set the "**Top Element**" and "**Bottom Element**" to 5.
4. Set "**Conveyor Speed**" to 5
5. Place food item on the conveyor.
6. Adjust as required: increase/decrease the "**Conveyor Speed**", "**Top Element**" and "**Bottom Element**". Repeat this process until the desired results have been achieved.
7. Once satisfied with the results, record the settings for future reference.
8. Repeat this process for different foods.

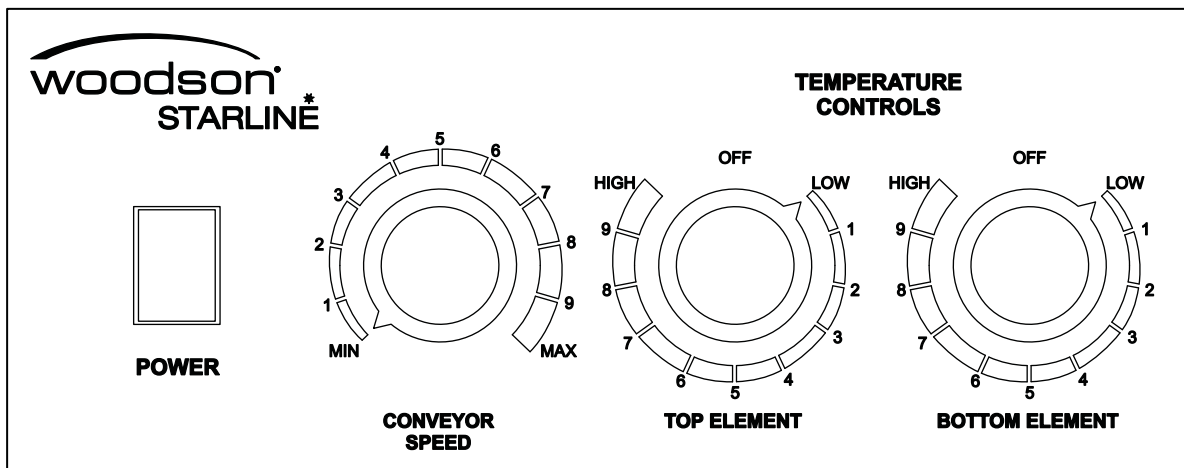

### Element Settings

Top Element only:

Best for Garlic bread, herb bread, focaccias and open snacks or browning the top of the product only.

Bottom Element only:

Best for single sided toasting of uneven products, such as Burger Buns.

Top and bottom Element:

Best for all types of standard breads, buns, focaccias and open snacks.

Note: Woodson Starline recommends that you time the belt speed from when the food item starts to enter the oven to when it starts to come out. This is the time the belt takes to pass through the oven.

Due to continuous product research and development, the information contained herein is subject to change without notice.

## Cleaning

### General Information



- Cleaning is recommended for health and safety purposes and to prolong the life of the appliance.
- Do NOT use abrasive pads or cleaners on the stainless steel or any other metal parts of the appliance .
- Do NOT use industrial chemical cleaners, caustic based cleaners or bleaches and bleaching agents, many will damage the metals and plastics used on this appliance.
- When drying, metal surfaces should be wiped with a soft cloth in the same direction as grained polish.
- Do NOT remove any screws for cleaning. All internal sections of the appliance are to be cleaned by a qualified technician.
- This unit is NOT waterproof, do NOT hose, do NOT pour water directly onto the unit.

### Corrosion Protection

- Stainless steel exhibits good resistance to corrosion however, if not properly maintained stainless steel can rust.
- Any sign of mild rust or corrosion should be thoroughly cleaned with warm soapy water and dried as soon as possible.
- NEVER use abrasive pads or cleaners for cleaning.
- All metal surfaces should be checked while cleaning for damage, scuffs or scrapes as these can lead to rust and further damage to the product.
- Medium rust or corrosion can treated with a commercial cleaning agent that contains citric/oxalic/nitric/phosphoric. Do NOT use cleaning agents with chlorides or other harsh chemicals as this can cause corrosion. After treatment, wash with warm (not hot) soapy water and dry thoroughly.
- Thoroughly wipe the surfaces dry after cleaning and do NOT let water pool on the appliance. Check crevices and folds for pooling.
- If an abrasive product is used while cleaning, thoroughly dry the unit and leave in an open or oxidised area for the stainless steel protective layer to replenish.
- When using, ensure all liquids and moisture is cleaned up straight away. Food liquids such as juices from vegetables and fruits should NOT be left on preparation surfaces.
- Do NOT leave items on the stainless steel such as cutting boards, rubber mats and bottles.

### Surface Finish

- To protect the polish, stainless steel should be dried by wiping a dry soft cloth in the same direction as grained polish.
- For NON-food contact surfaces, a light oil can be wiped on the surfaces with a cloth to enhance the stainless steel surface Wipe in the direction of the grain.
- Some commercial stainless stain cleaners can leave residue or film on the metal; this may trap fine particles of food on the surface, thus deeming the surfaces not food safe.

	<p style="text-align: center;"><b>WARNING!</b> This unit is <b>NOT</b> waterproof, do <b>NOT</b> hose. DO <b>NOT</b> pour water directly onto the unit.</p>
	<p style="text-align: center;"><b>Important!</b> Some commercial stainless stain cleaners leave residue or film on the metal that may entrap fine particles of food, thus deeming the surface not <b>FOOD SAFE</b>.</p>
	<p style="text-align: center;"><b>WARNING!</b> Wait until the unit has cooled to a safe temperature before undertaking any cleaning or maintenance. Contact with hot surfaces can cause burns and serious injury.</p>

Due to continuous product research and development, the information contained herein is subject to change without notice.

### **Cleaning Schedule**

- Daily cleaning is required for the oven conveyor, crumb tray and external surfaces. This will help to maintain and prolong the efficiency of your oven.
- The unit should be cleaned at the end of each work day.

### **Materials Required**

- Stainless Cleaner.
- Non Abrasive Cleaning pad.
- Clean Sanitised Cloth.
- Paper Towel.
- Container of warm water.
- Nylon Brush.
- Appropriate PPE (Personal Protective Equipment).

### **Cleaning Procedure - Conveyor and Crumb Tray**

1. Turn the unit off at the power switch.
2. Using a good quality nylon brush remove crumbs and small food items from the conveyor. (Switch the unit on to move the conveyor forward, then switch off).
3. Wipe clean using a cloth dampened (not wet) with clean warm water until all soil has been removed. (Switch the unit on to move the conveyor forward, then switch off).
4. Empty and clean the crumb tray. This should be done on a regular basis.

### **Cleaning Procedure - External Surfaces**

1. Turn the unit off and remove the electric cord from the power point, if hardwired turn off isolator switch.
2. Wearing Personal Protective Equipment (PPE), apply Stainless Cleaner with the Cleaner pad to the external surfaces.
3. Scrub any baked on soil with the cleaner pad in the same direction as grained polish.
4. Wipe clean using a cloth dampened with clean warm water until all Stainless Cleaner and soil has been removed.
5. Using a clean sanitised cloth, thoroughly wipe the stainless steel and metal parts dry. Do NOT let water pool on the unit. Check crevices and folds.

Note: In some areas, particularly seaside environments, stainless steel can be subject to surface discolouration or “tea staining”. This can be removed with an appropriate cleaning agent which contains 10% sodium citrate. Ask your supplier of cleaning chemicals for a suitable brand.

Due to continuous product research and development, the information contained herein is subject to change without notice.

## Troubleshooting

	<p><b>WARNING!</b> Technician tasks are only to be completed by qualified service people. Check faults before calling service technician.</p>
---	---

Task Type - (O) = Operator  
(T) = Technician Task

Problem	Possible Causes	Task	Possible Corrective Action
Unit won't turn on	Unit is not plugged into a suitable power point	O	Plug unit in
	Power switch is in the "Off" position	O	Change the power switch to the "ON" position
	Power Point is faulty	T	Arrange a qualified Technician to repair the power point
Conveyor not turning on	Conveyor Motor faulty	T	Lubricate / replace conveyor motor
	Conveyor speed dial not responding	T	Replace speed dial / Computer board (whichever is applicable)
	Bearings Worn	T	Replace Gear Head
Conveyor chain binds up in operation	Sprocket worn	T	Replace sprocket
	Belt loose	T	Remove a chain link
	Airflow blockage	O	Clear dirt / dust from fan guard and/or clear all air vents around the unit of any obstructions
Unit is overheating	Fan not working	T	Replace fan
	Elements not working	T	Replace Elements as required
Unit is not heating	Temp switch / Computer board not working	T	Replace switch / Computer board (whichever is applicable)
	Conveyor too slow	O	Adjust speed settings as required
Product is burning	Temperature set too high	O	Adjust temperature settings as required
	Conveyor is too fast	O	Adjust speed settings as required
Product is undercooked	Temperature is set too low	O	Adjust temperature settings as required

Due to continuous product research and development, the information contained herein is subject to change without notice.

## Appendix 1 – Australian Warranty and Contact Details

As the exclusive manufacturer and distributor of Stoddart products in Australia, Stoddart would like to congratulate you on your purchase of a Stoddart product.

It should be noted by users of the product that it is not designed for household or domestic use and should not be used for this purpose.

This product is intended for commercial use, and in line with Australian electrical safety standards the following warnings are provided:

- This product is not intended for use by persons (including children) with reduced physical, sensory or mental capabilities, or lack of experience and knowledge, unless they have been given supervision or instruction concerning the use of the product by a person responsible for their safety. Children should be supervised to ensure that they do not play with the product.
- If the supply cord is damaged, it must be replaced by the manufacturer, its service agent or similarly qualified persons in order to avoid a hazard. Please contact Stoddart for parts and we will advise how to do this in order to avoid any electrical hazard.

### Australian Warranty Policy & Procedure

Stoddart is committed to providing a comprehensive and fair warranty for all of its equipment. The warranty incorporates a commercial manufacturers' warranty, together with the consumer warranty provisions of the National Consumer Protection Act (2009).

#### 1. Commercial Warranty

- 1.1 Stoddart warrants to the original purchaser ("**Customer**") of equipment manufactured or distributed by Stoddart that for **12 months** from the date of installation of the equipment by Customer (the "**Warranty Period**"), any defect in workmanship or material will, subject to clauses 1.2 and 3, be:
  - a) Repaired without charge; or
  - b) In respect of any **Major Failure** which cannot be repaired, replaced or the purchase money refunded.
- 1.2 Stoddart will not be liable for any associated loss, damage or compensation claim resulting from any defect in workmanship or material, and such liability is expressly excluded from the operation of clause 1.1.

#### 2. Consumer Warranty

- 2.1 Subject to clause 3, equipment supplied by Stoddart to Customer for personal, domestic or household use or consumption comes with guarantees that cannot be excluded under the Australian Consumer Law. Customer is entitled to a replacement or refund for a **Major Failure** and compensation for any other reasonably foreseeable loss or damage. Customer is entitled to have the equipment repaired, or replaced if the equipment fails to be of an **Acceptable Quality** and that failure does not amount to a Major Failure.

#### 3. Warranty Clarification

- 3.1 Customer acknowledges and agrees:
  - i. A **Major Failure** occurs when the equipment suffers repeated and/or unexpected failure that cannot be repaired to Stoddart's satisfaction (acting reasonably) or which Stoddart considers (acting reasonably) renders the equipment unsafe or inoperable;
  - ii. Stoddart can only warrant the equipment will be of an **Acceptable Quality** when Customer uses the equipment in accordance with Stoddart's manufacturer's instructions or user manual ("**Instructions**"). Acceptable Quality does not imply a lifetime guarantee for the equipment;
  - iii. Certain components have a finite expected life, especially in a commercial or high-use environment. For example components such as refrigeration compressors, elements, thermostats/simmerstats, switches, fans, and temperature controllers can be expected to last up to **12 months** when used in accordance with the instructions;
  - iv. In a commercial environment, components such as lamps, fluorescent tubes, light bulbs, glass, silicone seals, gaskets and plastic components will require regular replacement. This is not covered by warranty and is at Customer's cost.;
  - v. The life of equipment may be adversely affected by misuse, neglect, unauthorised alteration, incorrect installation, power surges, accident, use of inappropriate chemicals, flooding, and acts of God;
  - vi. Proper maintenance and cleaning of equipment in accordance with the Instructions is essential to the equipment's effective operation;
  - vii. On site warranty services are limited to sites within 50km from the nearest Stoddart authorised service agent and service agent's reasonable travel costs must be paid by Customer prior to the commencement of the repairs;
  - viii. Additional labour costs will apply for service outside standard business hours of 8.00am to 4:30pm, Monday to Friday and on public holidays;
  - ix. Stoddart cannot guarantee the performance of equipment made specifically to Customer's design or specifications. Stoddart will, where reasonably possible, draw any issues arising from Customer's design or specifications to Customer's attention during the commissioning and/or manufacturing process; and
  - x. Customer must pay additional costs incurred by Stoddart as a result of Customer failing to provide suitable access to the equipment for inspection and service.

3.2 Stoddart's warranty liability under clauses 1 and 2 of these Terms exclude or do not cover:

- a) The matters acknowledged by Customer in clause 3.1;
- b) Situations where Stoddart is not satisfied (acting reasonably) the equipment or any part of the equipment has been used in accordance with the Instructions including misuse, neglect, unauthorised alteration, incorrect installation, power surges, accident, use of inappropriate chemicals, flooding, fire or act of God;
- c) Any consequential loss, damage or expense arising directly or indirectly from use of the equipment otherwise than in accordance with the Instructions;
- d) Any damage or malfunction arising from, or relating to, Customer's failure to properly maintain or clean the equipment in accordance with the Instructions;
- e) Damage caused to equipment during transportation, which is outside Stoddart's standard delivery conditions.
- f) Breakage or replacement of lamps, fluorescent tubes, light bulbs, glass, silicone seals, gaskets and plastic components.;
- g) Maintenance, repair or other works not undertaken by a Stoddart authorised service agent.
- h) Where remote refrigeration is connected by a person other than Stoddart to equipment produced by Stoddart, Stoddart cannot accept claims for repair of TX valves and control components, as the fault may arise from the installation of the remote refrigeration lines, equipment, and gas, by a party over which Stoddart has no control.
- i) Transportation costs associated with transporting the equipment to a Stoddart authorized service agent where Stoddart considers (acting reasonably) that repairs cannot be undertaken on-site; and
- j) Unless agreed to by Stoddart in writing to the contrary, warranty is not included in the sale price for goods sold to or installed in an overseas location.

## 4. Warranty Claim Procedure

4.1 The following procedure must be followed to claim under Stoddart's warranties:

- a) Refer to the trouble-shooting section of the Instructions to establish the nature of the fault. Check the equipment is plugged-in, turned-on or has no other valid reason for not operating.
- b) If step (a) does not overcome the issue, you should report the fault with the equipment to our service department (phone 1300 307 289 or fax 07 3344 6166). Our service department will assist you with further trouble-shooting. If our service department is unable to resolve the fault with the equipment they will request you complete a Stoddart Warranty Request Form and fax (07 3344 6166) or email (service@stoddart.com.au) it to us. This form can also be completed online ([www.stoddart.com.au/warranty-claim](http://www.stoddart.com.au/warranty-claim)).
- c) To complete a Stoddart Warranty Request Form you will require the following information:
  - I. Proof of purchase stating model number and date of purchase;
  - II. The serial number of the equipment (this is located on the ratings plate sticker);
  - III. A description of the fault/problem;
  - IV. Your company details including the exact location of the equipment; and
  - V. Any restrictions on times or methods of access to the equipment.

Stoddart will not arrange a warranty call out until it receives the above information from you in writing.

- d) Upon receipt of a properly completed Stoddart Warranty Request Form, Stoddart will check its records to confirm whether the equipment is eligible for warranty repair. If warranty repair is required, Stoddart will issue an OFFICIAL AUTHORISATION NUMBER and details of work to be carried out by a Stoddart authorised service agent. This authorisation number MUST be obtained before any work is carried out. Stoddart will not accept invoices for work carried out without an official authorisation number or by an unauthorised service agent.
- e) Customer must quote the official authorisation number on all correspondence and invoices relating to a warranty claim to ensure prompt processing by Stoddart.
- f) Customer must pay all costs associated with a call-out for work that is not related to warranty repairs or outside Stoddart's Terms immediately.

## 5. Timing of Warranty Services

5.1 Stoddart will comply with its warranty liabilities contained in these Terms in a timely manner.

## 6. General Maintenance and Repairs

6.1 The equipment must be repaired and maintained by a qualified technician. Stoddart's authorised service agents are experienced technicians who understand the equipment and carry commonly used spare parts. Contact Stoddart's national service number listed below for details of your nearest Stoddart authorised service agent.

**For Warranty, maintenance, spare parts and repairs, contact:  
Tel: 1300 307 289 Fax: 07 3344 6166 email: [service@stoddart.com.au](mailto:service@stoddart.com.au)**



This form can also be completed online at: [www.stoddart.com.au/warranty-claim](http://www.stoddart.com.au/warranty-claim).

### WARRANTY REQUEST FORM



Phone: (07) 3440 7600 Int: +617 3440 7600  
Phone: 1300 307 289  
Fax: (07) 3344 1000 Int: +617 3344 1000  
Email: [service@stoddart.com.au](mailto:service@stoddart.com.au)

To ensure we can provide the best possible service we require you to complete this form. Make, model and serial number, along with other essential information. To secure a call, you must also have an account with Stoddart or complete the credit card details below.  
**THIS FORM MUST BE COMPLETED OR WARRANTY CANNOT BE PROCESSED**

Name of contact person on site: \_\_\_\_\_ Date: / /  
Business/Organisation name: \_\_\_\_\_  
Street Address: \_\_\_\_\_  
Suburb: \_\_\_\_\_ State: \_\_\_\_\_ Post Code: \_\_\_\_\_  
Phone (Site): \_\_\_\_\_ Mob: \_\_\_\_\_  
Equipment Type: \_\_\_\_\_ Brand: \_\_\_\_\_  
Model/PNC no.: \_\_\_\_\_ Serial no.: \_\_\_\_\_  
Location (large sites only): \_\_\_\_\_ Open: \_\_\_\_\_ Close: \_\_\_\_\_  
Date of purchase: / /  
Company purchased from: \_\_\_\_\_  
(please provide a copy of your tax invoice or delivery docket as proof of purchase)  
Description of fault: \_\_\_\_\_  
\_\_\_\_\_  
\_\_\_\_\_

Has the following been checked (tick box if appropriate and checked)?

Electrical power supply  Gas  Water Supply

Name of person requesting warranty (please print): \_\_\_\_\_

**CREDIT CARD DETAILS – Required as security against chargeable work (see note below)**  
Card type: Visa  Mastercard   
Cardholder name: \_\_\_\_\_ Card no.: \_\_\_\_\_  
Signature: \_\_\_\_\_ Expiry Date: / /

PLEASE NOTE: Warranty call-outs take place Mondays to Fridays between 8.00 and 16.30 (except public holidays). Any calls outside these times will be subject to penalty rates. Certain items such as glass components and light fittings are not covered under warranty. Claims for non-covered parts, no faults found, travel over 50km or other items outside our standard terms and conditions will be chargeable. Any chargeable items will be COD terms – payable onsite.

**CREDIT CARD INFORMATION MUST BE PROVIDED AS SECURITY AGAINST FALSE WARRANTY CALL-OUTS.  
FAILURE TO DO SO WILL RESULT IN REQUEST BEING UNATTENDED.  
NORMAL BUSINESS HOURS ARE 8AM – 4.30PM MONDAY TO FRIDAY**



***Stoddart Sales  
Servicing and Replacement***

**Sales Department**

Tel: 1300 791 954

Fax: (07) 3344 1000

Email: [fseorders@stoddart.com.au](mailto:fseorders@stoddart.com.au)

**Service & Spares Department**

Tel: 1300 307 289

Email: [service@stoddart.com.au](mailto:service@stoddart.com.au)

Email: [spares@stoddart.com.au](mailto:spares@stoddart.com.au)



woodson®  
STARLINE\*



STODDART®

[www.stoddart.com.au](http://www.stoddart.com.au)