

Square Profile Hot Food Display

The Woodson square profile hot food display combines market leading features and aesthetically pleasing modern styling.

Combining these market leading features has resulted in rear ventilation, that reduces condensation build up on the front glass.



Quartz infra-red overhead heat lamps



Glass doors to rear of unit



Precise thermostat control

FEATURES & BENEFITS

- Stainless steel construction with dual skin air-insulated bain marie tank for improved safety
- Square profile design with toughened glass gantry
- Custom designed rear ventilation that allows moisture to escape, preventing condensation on front viewing glass
- Multiple element design means unit will continue to operate in the event of single element failure
- Supplied with rear sliding glass doors on rollers for council compliance
- Thermostat controls with clear temperature readout
- 20mm drain with downward emptying tap
- Overhead heat lamps wired to maximise light, heat and reliability - with lamp guard
- Full size gastronorm cavity to take choice of 65mm and 100mm pan combinations (pans not included)
- Easy to service via rear access panel
- Identical footprint to other Woodson food display models
- Can be run both wet and dry
- 2 & 3 bay supplied with 10 amp plug & lead
- 4, 5 & 6 bay supplied with 15 amp plug & lead



W.HFSQxx



Square Profile Hot Food Display

MODEL	DESCRIPTION	DIMENSIONS (mm) (w x d x h)	POWER
W.HFSQ22	2 module unit with rear sliding glass doors	705 x 600 x 702	1.5kW - 10 Amp
W.HFSQ23	3 module unit with rear sliding glass doors	1030 x 600 x 702	2.4kW - 10 Amp
W.HFSQ24	4 module unit with rear sliding glass doors	1355 x 600 x 702	3.0kW - 15 Amp
W.HFSQ25	5 module unit with rear sliding glass doors	1680 x 600 x 702	3.3kW - 15 Amp
W.HFSQ26	6 module unit with rear sliding glass doors	2005 x 600 x 702	3.6kW - 15 Amp

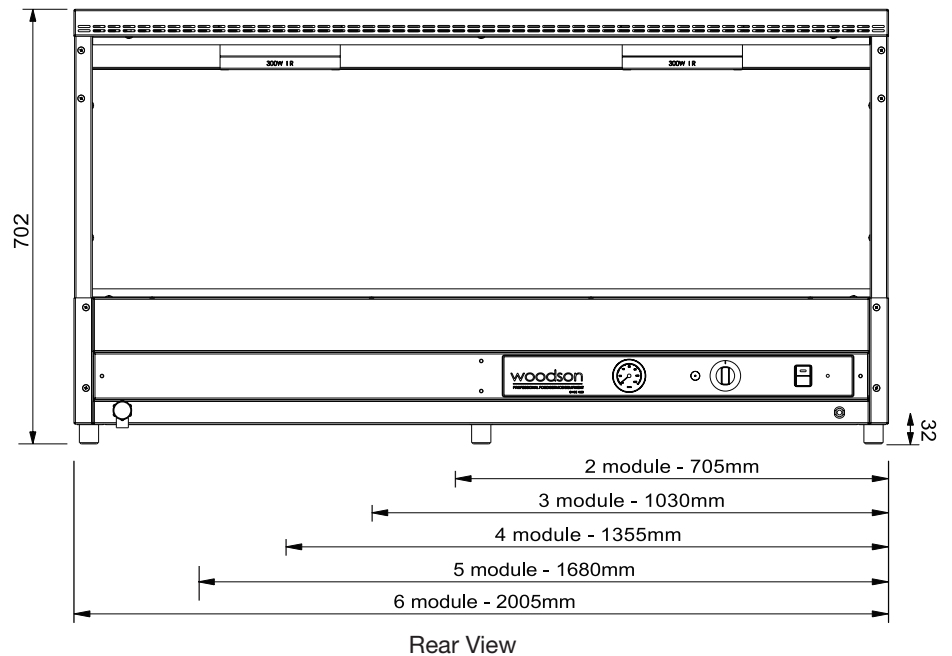
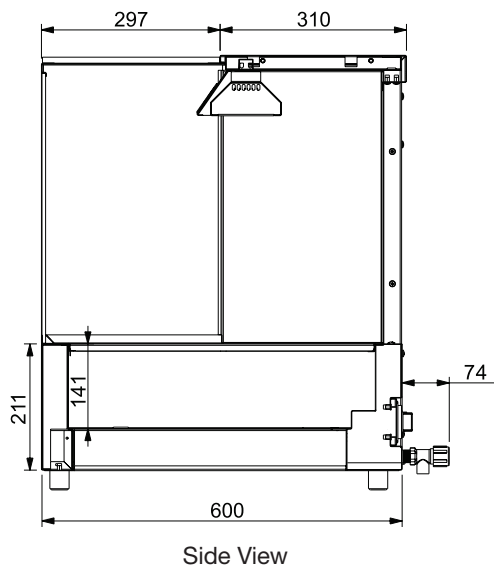

Dealer:

We reserve the right to alter specifications of products without notice. All dimensions are in mm.